



PV-MODULE MOUNTING TP

SUN-RAC LT SERIES

INSTALLATION MANUAL FOR 4.0" SCH 40



REV1.120518



CONTENT

- 1.SUN-RAC GENERAL REFERENCES PAGE 3
- 2.ADDITIONAL INSTALLATION ITEMS – PIPE DIMENSIONS PAGE 3-4
- 3.PARTS LIST PAGE 4-5
- 4.PLANNING PAGE 5-6
- 4.2 REQUIRED TOOLS PAGE 6
- 5.MOUNTING PAGE 7
- 5.2 TORQUE TABLE PAGE 7
- 5.3 CALCULATING CUSTOM CROSS BEAM LENGTH..... PAGE 7
- 5.4 INSTALLATION OF SUN-RAC PAGE 8-10
- 5.5 ADJUSTMENT OF ANGLE OR ARRAY PAGE 11



“The SUN-RAC system is the fastest most cost effective top of pole mounting system we have used. I wish this racking solution was available years ago. It doesn’t matter what solar panels I have on hand, the SUN-RAC system fits them all!”

SUN-RAC SRTP-PM-X LT SERIES //

1 - SUN-RAC GENERAL REFERENCES

This installation guide contains important information which should be read and understood before installation and start-up. For safe and reliable operation, the entirety of this guide should be considered essential reading as safety and operational information is provided in all sections, not only in the "safety references" section. Both the installer and person responsible for the on-going operation should read and understand this guide. This guide should always be available at the installation site. This installation guide refers to the PV-module mounting system SRTP-PM-X only.

The total PV-module area of the PV-modules must not exceed 91 ft². The maximum width of the PV-modules, including the distances between the PV-modules must not exceed 205 inches and the height must not exceed 67 inches with the combined maximum surface area of 91 ft². PV-modules certified to IEC 61215 or UL 1703 must be installed vertically. If the PV modules are not certified to IEC 61215, UL 1703 then care should be taken to assess the suitability for mounting onto the sub-structure of the SRTP-PM-X.

The customer must consider the local weather conditions and the suitability of the SRTP-PM-1-X to operate in these conditions. The Pole Mount structure is designed to perform with a maximum wind speed of 80mph. The maximum ice thickness is 1inch at maximum windspeed. Snow thickness equivalence of the ice thickness will vary from 2 inch to 12 inches depending on local conditions. Where modules are installed in non-equatorial regions then the tilt angle of the modules will reduce the likelihood of high snow thickness.

ALL WARRANTY CLAIMS AGAINST SUN-RAC ARE INVALID IF THE SRTP-PM-X IS INSTALLED IN INAPPROPRIATE CONDITIONS.

2 – ADDITIONAL INSTALLATION ITEMS AND PIPE DIMENSIONS

The Pole Mount SRTP-PM-X mounting structure does not include a main pole or cross beam.

- The cross beam must be supplied separately (not included) Cross Beam Pipe Size Requirement: is 4.0 inch Nominal, 4.5" inch O.D. Steel Pipe Minimum Wall thickness: Schedule 40 or 0.225 inch See below for Cross Beam required length.

The main pole must be supplied separately (not included)

- Main Pole Pipe Size Requirement: is 4.0 inch Nominal, 4.5 inch O.D. Steel Pipe Minimum Wall thickness: Schedule 40 or 0.225 inch Pipe length minimum length: 120.0 inches (10 ft.) See page 6 for depth and hole requirements for main pole.

Cross Beam Lengths Minimum

Lengths shown below. (See 5.3 for exact calculations)

BEAM	PM-1	PM-2	PM-3	PM-4	PM-5	PM-6
5" CELL	36"	70"	104"	133"	172"	205"
6" CELL	42"	83"	124"	165"	206"	248"

Overall Dimensions

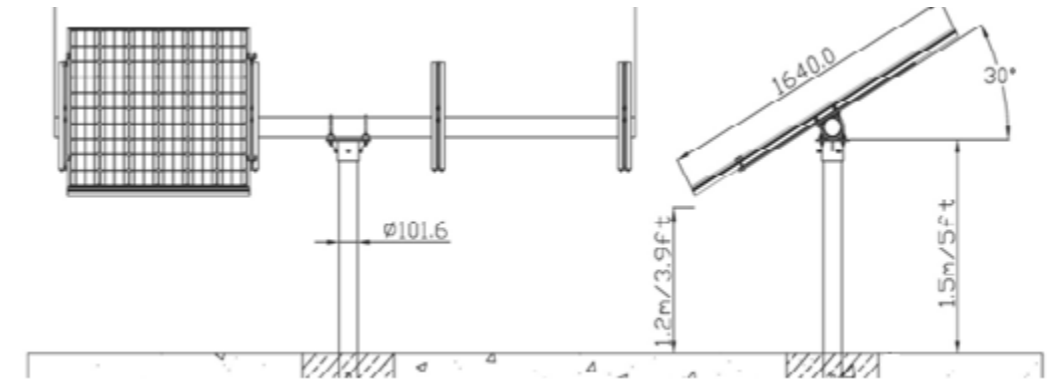

101.6 mm = 48 inches
1640mm = 64.57 inches

A – Not to

3 - PARTS LIST

LIST NO.	PART	QUANTITY OF PARTS FOR EACH PM-1-X					
		PM-1	PM-2	PM-3	PM-4	PM-5	PM-6
1	MAIN POLE, 4.5 INCH O.D.	1	1	1	1	1	2(*)
2	4.5 INCH O.D. POLE CAP	1	1	1	1	1	2(*)
3	M10X25 BOLT	3	3	3	3	3	6
4	BEAM BRACKET	4	5	6	7	8	9
5	CROSS BEAM	1	1	1	1	1	1
6	M10 U-BOLT	4	5	6	7	8	9
7	M10 WASHER (SPRING & FLAT)	8	10	12	14	16	18
8	M10 NUT	8	10	12	14	16	18
9	PURLIN MOUNT	2	3	4	5	6	7
10	END CLAMP (35,40&50MM PROVIDED)	12	12	12	12	12	12
11	MID CLAMP	0	2	4	6	8	10

(*) REQUIRES QTY. 2, 4.0 INCH CAP ASSEMBLIES AND MAIN POLES FOR 5" AND 6" CELLS

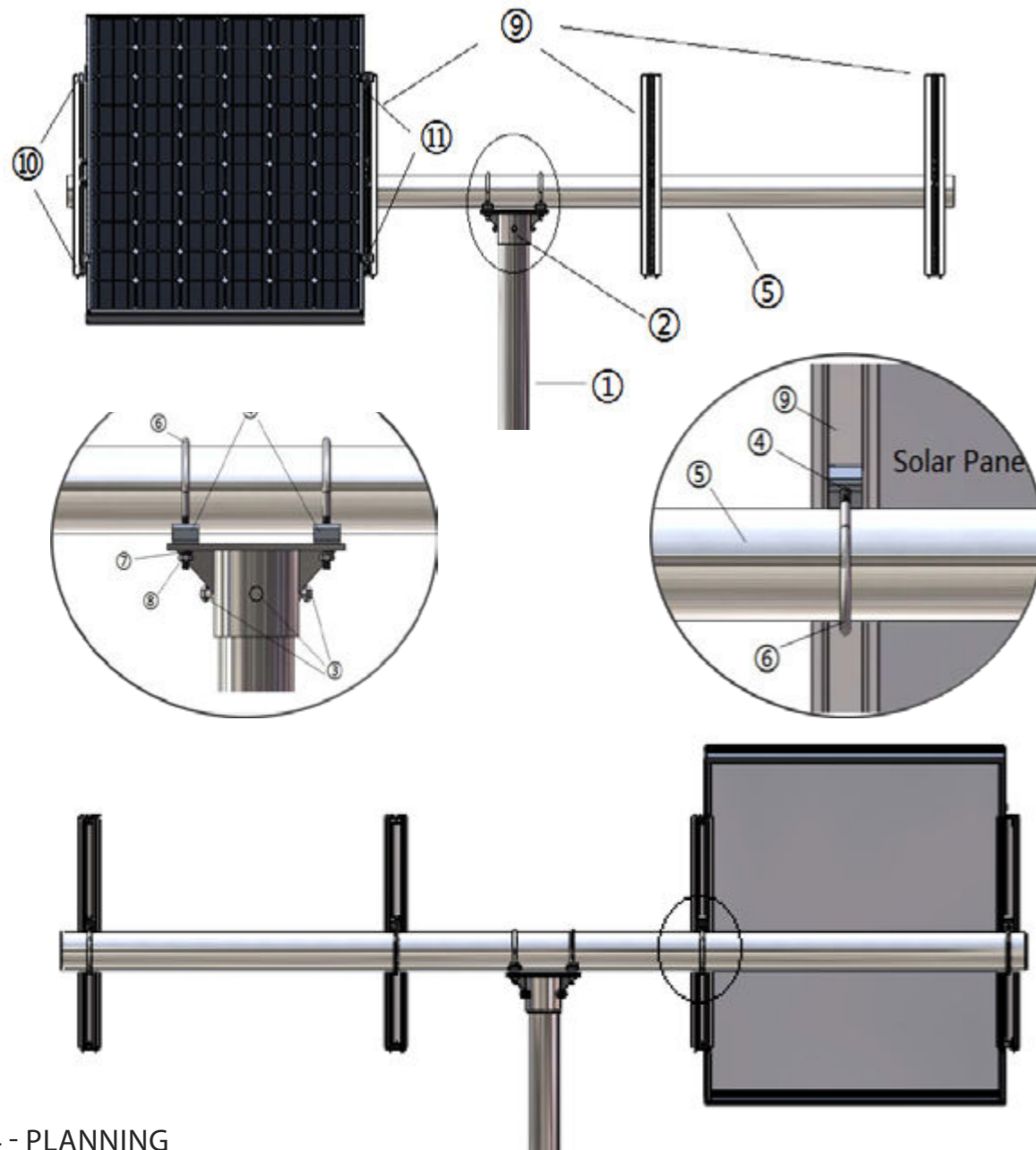

4 - PLANNING

- "RULE OF THUMB" GUIDELINES FOR AVERAGE MOUNTING POLE INSTALLATION:
- IT IS THE INSTALLERS RESPONSIBILITY TO VERIFY SOIL CONDITIONS.
- SOIL CONDITIONS VARY FROM REGION TO REGION
- SOIL CONDITIONS WILL DETERMINE THE ACTUAL DEPTH AND DIAMETER OF THE HOLE AND AMOUNT OF CONCRETE USED.
- IF YOU ARE UNCERTAIN WE RECOMMEND YOU CONSULT A CIVIL ENGINEER IN YOUR AREA WHO IS FAMILIAR WITH LOCAL SOIL CONDITIONS AND WIND
- INSTALL MOUNTING POLE SO IT IS RESTING ON THE BOTTOM OF THE HOLE
- FILL THE BOTTOM 2" - 4" WITH GRAVEL TO ALLOW WATER DRAINAGE
- BRACE THE MOUNTING POLE SO THAT IS PLUMB
- FILL THE HOLE WITH CONCRETE, ADDING 2" - 3" ADDITIONAL TO SLOPE AWAY FROM POLE FOR DRAINAGE (FORM WITH TROWEL)
- ALLOW THE CONCRETE TO SET FOR A MINIMUM OF 24 HRS BEFORE REMOVING BRACING AND.

INSTALLING RACKING SYSTEM.

Mounting Pole Requirements

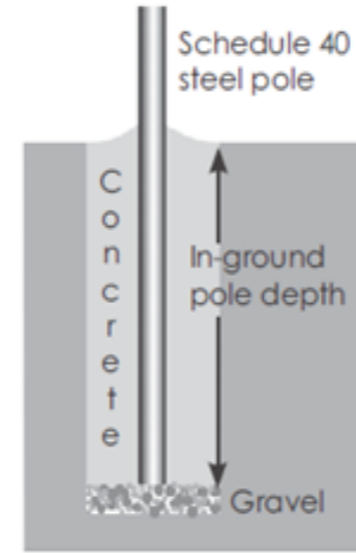

Total module area	Design wind speed	Metric		
		Hole diameter	In-ground pole depth	Concrete volume
4sq.m	150km/h	50cm	115cm	0.22m ³
4sq.m	200km/h	60 cm	140cm	0.39 m ³
5 sq.m	150km/h	60 cm	100cm	0.28 m ³
5 sq.m	200km/h	60 cm	170cm	0.48 m ³
6 sq. m	150 km/h	60 cm	120 cm	0.34 m ³
6 sq. m	200 km/h	70 cm	155 cm	0.59 m ³
7 sq. m	150 km/h	60 cm	140 cm	0.39 m ³
7 sq. m	200 km/h	70 cm	175 cm	0.67 m ³
8 sq. m	150 km/h	60 cm	160 cm	0.45 m ³
8 sq. m	200 km/h	70 cm	205 cm	0.78 m ³
9 sq. m	150 km/h	60 cm	175 cm	0.50 m ³
9 sq. m	200 km/h	70 cm	225 cm	0.87 m ³
11 sq. m	150 km/h	60 cm	215 cm	0.60 m ³
11 sq. m	200 km/h	80 cm	200 cm	1.00 m ³

Assumptions: The pole extends no more than 6 feet(1.8 meters) above ground, Design wind speeds assume 29 psf wind force at 90mph (150km/h) and 51 psf wind force at 120 mph(200km/h).which correspond to Exposure Category C of the International Building Code, terrain that is flat and generally open extending one-half mile(800 meters) or more from the site in any quadrant.

4.2 - REQUIRED TOOLS FOR INSTALLATION:

- 6mm, Allen key
- Ring or open end flat spanner, wrench size 17mm
- Socket nut (1/2"-drive) for wrench size 17mm
- Ratchet spanner 1/2"
- Torque wrench 1/2" (needed torque 32 Nm/23.6 lb-ft)
- Measuring tape 25 ft.
- Marker for steel
- Safety shoes, helmet and safety equipment for lifting and handling steel parts over head
- Oil for the screws

5 - MOUNTING

The Pole Mount SRTP-PM-1-x is designed to require minimum servicing or maintenance work. For safe and reliable operation the system should be checked regularly.



WE RECOMMEND THAT NUTS, BOLTS AND SCREWS ARE CHECKED FOR APPROPRIATE TIGHTNESS 6 MONTHS AFTER INSTALLATION, AND THEN EVERY YEAR.

All nuts, bolts and connection parts are stainless steel to strength class 70. If any parts are replaced they should be replaced with parts of the same specification.
All data provided is based on the manufacturer's specifications.

This manual is an installation guide and does not replace good engineering practice. The local installer should check and verify the installation carefully.

5.2 TABLE OF REQUIRED TORQUE

Nominal torque for the bolts of the PM2-X.

Screw/Nut dimension	Strength class	Torque[Nm]
M10	A2-70	32 [Nm] , 23,6 [lb-ft]

5.3 CALCULATION OF THE BEAM LENGTH AND INSTALLATION DIMENSIONS

This rack is adjustable for different sizes of PV-modules. To assemble the Pole-Mount some dimensions have to be calculated. Ascertain the right installation dimensions as follows:

1. Find the right PV-Module width "W".
2. Write down the number of PV-Modules you want to mount. "N"
3. Calculate the Beam length L1



EXAMPLE:

Number of PV-Modules N = _____

Width of the PV-Module W = _____

L1 = _____ IN. $N \times W + (N - 1) + 6$ INCHES = _____ IN.

5.4 INSTALLATION OF THE SUN-RAC TOP POLE-MOUNT PM-1-X

Parts of the mounting system are very heavy so care must be taken during handling, unpacking and installation. Appropriate safety equipment including safety gloves and safety shoes must be worn at all times.

Please follow the steps below for the Installation of the SUN-RAC Top Pole Mount

1. Starting Situation. The Pole is fitted into the Ground



2. Place the Cap on the Pole and adjust in to South. The long axis of the Cap should be oriented to East/West direction.



3. Fix the Cap with three Bolt M10x25 to the Pole. Please use a torque wrench (32Nm).



4. Lay the Beam on the Cap.



5. Place the Cross Beam Bracket under the Beam, insert the U-bolt (6) into the holes and through the Rack Head, connect M10 washers and lock washers and Nuts. tighten them lightly.

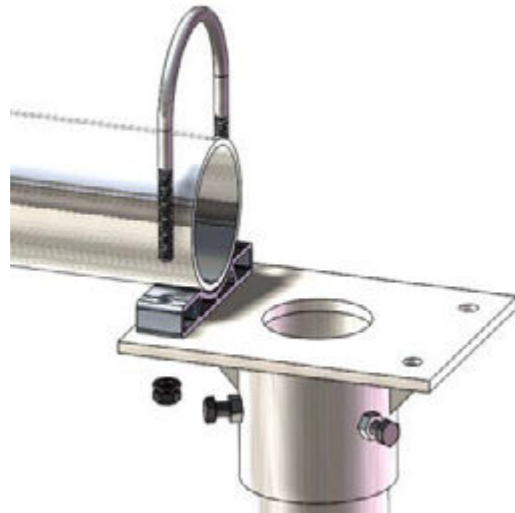

6. Slide the Beam symmetrical onto the Cap. Make sure the marked middle of the Beam is in the middle of the Cap. Place the second Beam Washer under the Beam and mount it as shown in the picture below:



7. Mount one of the Purlin at a Tilt-angle of 0° The W= Panel's Width+24mm[0.95 inch]

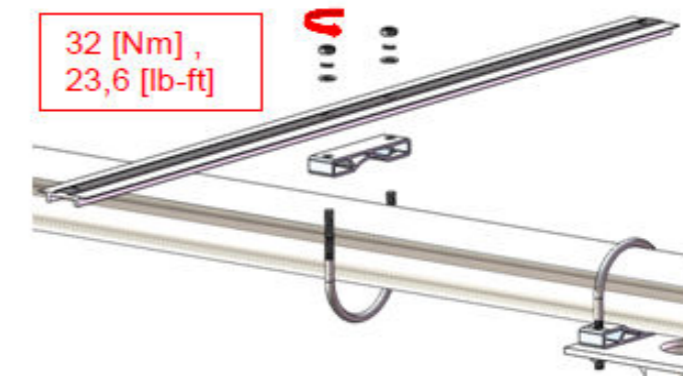

6. All purlins installed equal distance as shown below.

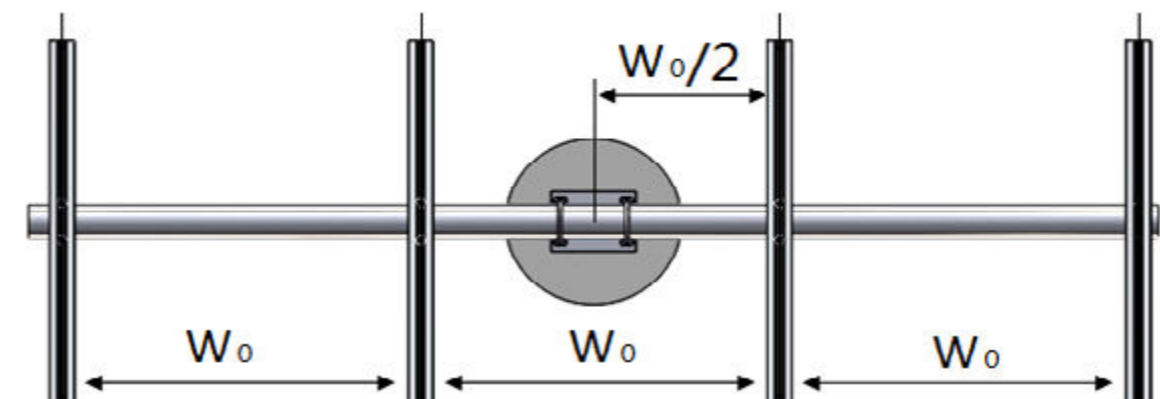

(ThreeModuleSRTP-PM-3)

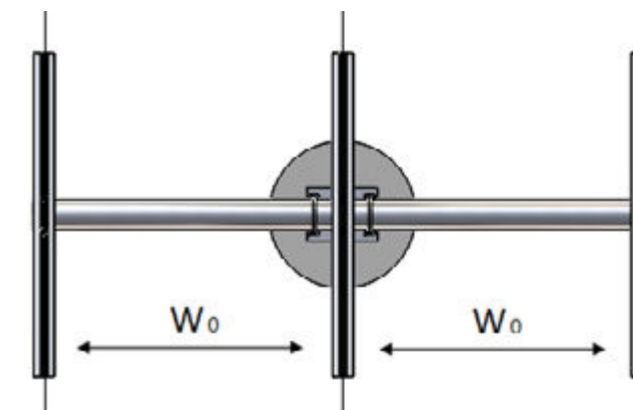

(TwoModuleSRTP-PM-2)

8. Installed the Solar Panel on the Purlin.

a. installed the First Panel (start on either end) with the End Clamp(M8*25 Bolt & Spring washer).

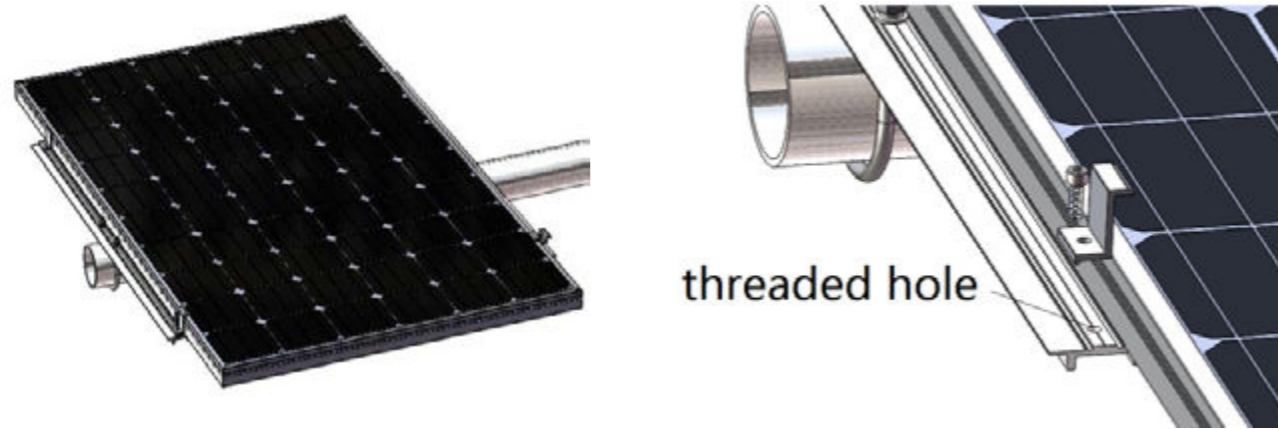

b. Installed the second Panel with the Mid Clamp(the Bolt's length is the Panel's thickness+10mm; e.g.1640*990*40mm Panel, the Bolt is M8*50 with Spring washer).

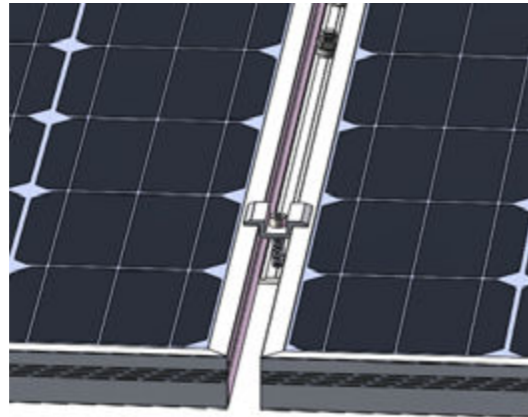

C. Finished the installation with the End Clamp.



5.5 ADJUSTMENT OF THE TILT-ANGLE

L3 is the measurement between the lower end of the Rail and the Pole. Please Measure from the edge shown below edge on the Rail to the Pole. Adjust angle by loosening u-bolts through the top-cap

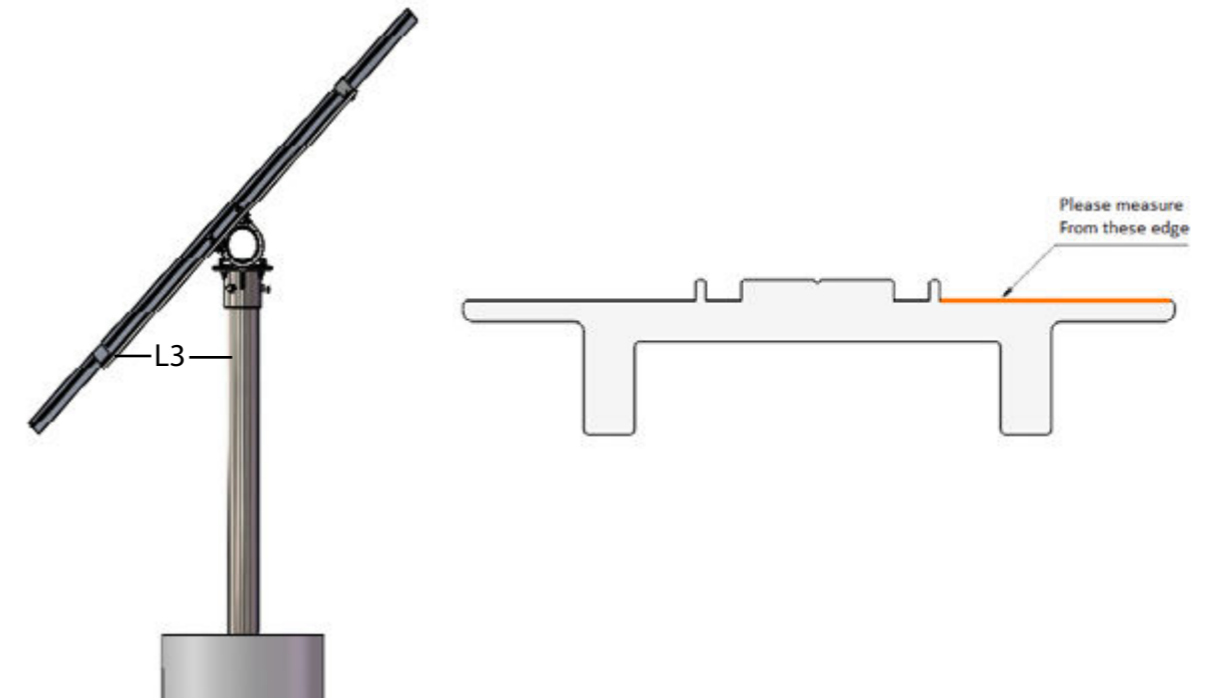

The tilt adjustment for the northern hemisphere is shown below. (Adjust accordingly for southern hemi-sphere):

Year Round Compromise Tilt Angle = Degree of Latitude
 Summer Tilt Angle = Latitude -15 Degrees
 Winter Tilt Angle = Latitude + 15 Degrees

NOTES ON INSTALLATION:

Make sure that a galvanized steel pipe is used so that all rust and corrosion is inhibited. If galvanized pipe is not used, make sure that all exposed steel surfaces are painted for the environmental conditions presented.

DO NOT:

Use plastic pipe for cross beams or main pole.

Use aluminum pipe for cross beam or main pole.

Shipping Weights/Dimensions:

Model:	Shipping Weight:	Box Dimensions:
SUN-RAC SRTP-PM-1	18 lbs.	36 in x 10 in. x 10 in.
SUN-RAC SRTP-PM-2	21 lbs.	
SUN-RAC SRTP-PM-3	23 lbs	
SUN-RAC SRTP-PM-4	25 lbs.	
SUN-RAC SRTP-PM-4	28 lbs	
SUN-RAC SRTP-PM-6	39 lbs	

All racks are UPS or FEDEX approved for shipping.

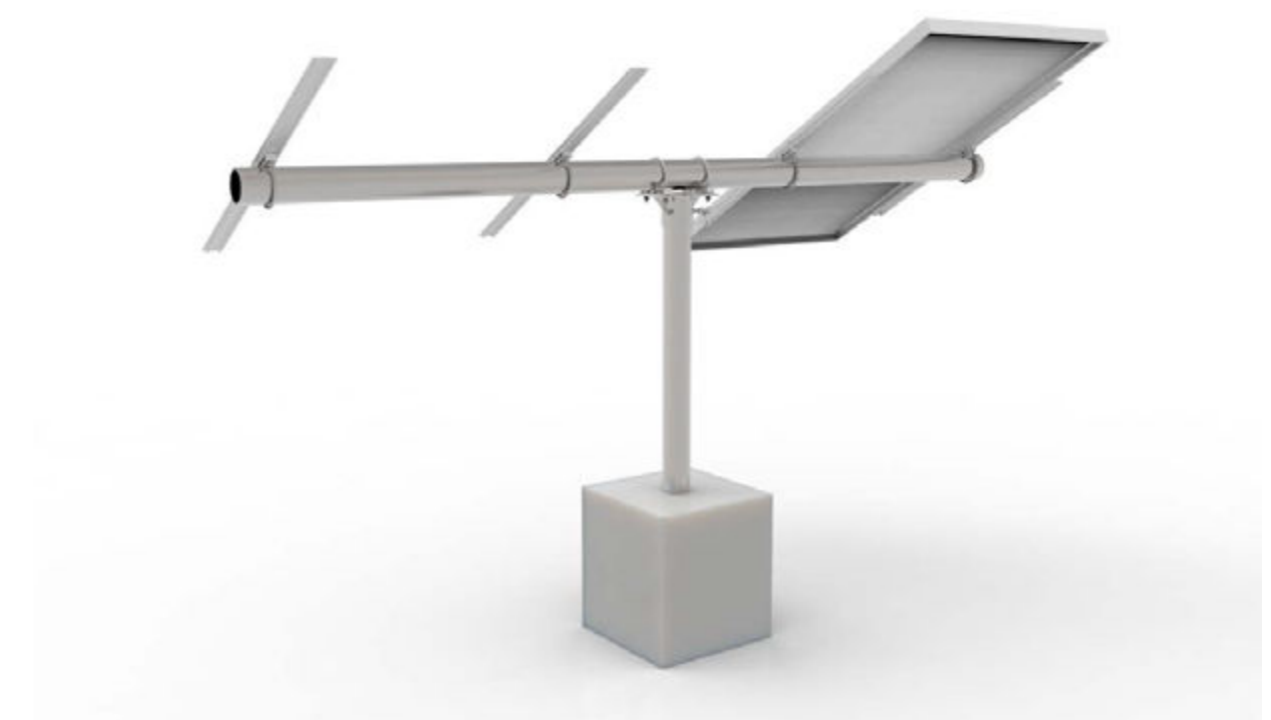



Simply. Energy.

© 2016 All Rights Reserved.