



SC30 / SC30-LVD (SUN CHARGER 30 PWM)

12VDC 30AMP PULSE WIDTH MODULATED
PHOTOVOLTAIC CHARGE CONTROLLER

INSTALLATION AND OPERATION MANUAL



CONFORMS TO:
EN 61000-6-2:2005
EN 61000-6-3:2007 + A1:2011
AS/NZS 60000-6-3:2012

FCC CFR 47 Part 15 Subpart B
This device complies with part 15 of the FCC rules. Operation is subject to the following two conditions: 1) This device may not cause harmful interference, and 2) This device must accept any interference received, including interference that may cause undesired operations.

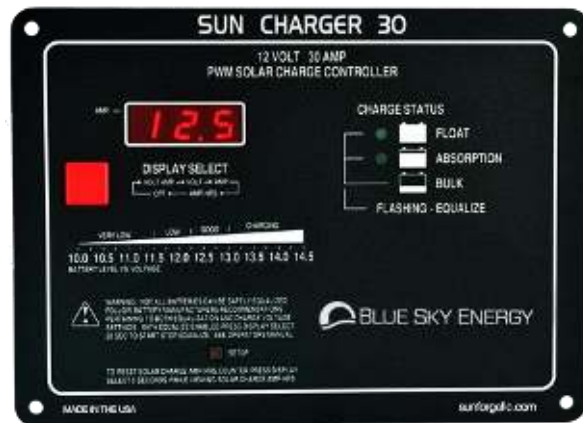

THIS MANUAL INCLUDES IMPORTANT SAFETY INSTRUCTIONS FOR MODELS SC30 AND SC30-LVD
SAVE THESE INSTRUCTIONS.

TABLE OF CONTENTS

IMPORTANT SAFETY INSTRUCTIONS 2

PRODUCT DESCRIPTION 2
 Part Numbers and Options 2

OPERATION 3
 Charge Status Indication 3
 Digital Display..... 3
 Solar Charge Amp-Hour Counter 3
 Battery Level Graphic..... 3
 3-Stage Charge Control 4
 Bulk Charge 4
 Absorption Charge 4
 Float Charge4
 Two Stage Charge Control.....4
 30 Amp Current Limit..... 4
 Optional Temperature Compensation 5
 Equalization..... 5
 Maximum Setpoint Voltage Limit 5
 Pulse Width Modulation 5
 Panel Temperature and Thermal Protection 6
 Load Control And Lighting Control (SC30-LVD version only)..... 6

INSTALLATION 6
 Charge Parameter Settings 6
 As Shipped Factory Default Settings 6
 Restoring As Shipped Factory Default Settings 6
 Changing Charge Parameter Settings 7
 Selecting PV Modules..... 7
 Battery and PV Wiring..... 8
 Optional Battery Temperature Sensor..... 9
 Battery & PV Power Connect/Disconnect Order 9
 Connecting The Battery..... 9
 Connecting PV Modules 9
 Mounting 9

TROUBLESHOOTING GUIDE10



SPECIFICATIONS 11

FIVE YEAR LIMITED WARRANTY..... 11

TABLES AND FIGURES
 Table 1 Charge Status 3
 Table 2 Charge Parameter Settings..... 7
 Table 3 Maximum Conductor Pair Length – 3% Voltage Drop 8
 Figure 1 Front Panel Operation & Indicators 4
 Figure 2 Factory Charge Voltage Setpoints -vs.- Battery Temperature 5
 Figure 3 Wiring Diagram 8
 Figure 4 Detailed Dimensional Drawing 9

IMPORTANT SAFETY INSTRUCTIONS**This manual contains important instructions for Models SC30 and SC30-LVD - SAVE THESE INSTRUCTIONS**

1. Refer installation and servicing to qualified service personnel. Incorrect installation or use may result in risk of electric shock or fire. No user serviceable parts in this unit.
2. To reduce the risk of electric shock, fire or personal injury, the following symbols are placed throughout this manual to indicate dangerous conditions, or important safety or operational instructions.

WARNING	CAUTION	IMPORTANT
		
Indicates dangerous conditions or electric shock potential. Use extreme caution.	Indicates items critical to safe installation or operation of the unit.	Follow these instructions closely for proper operation of the unit

3. PERSONAL PRECAUTIONS

- a) Working in the vicinity of lead-acid batteries is dangerous. Batteries produce explosive gases during normal operation.
- b) To reduce risk of battery explosion, follow these instructions and those published by battery manufacturer and manufacturer of any equipment you intend to use in vicinity of battery.
- c) Someone should be within range of your voice or close enough to come to your aid when you work near a lead-acid battery.
- d) Have plenty of fresh water and soap nearby in case battery acid contacts skin, clothing or eyes.
- e) Wear complete eye protection and clothing protection. Avoid touching eyes while working near battery.
- f) If battery acid contacts skin or clothing, wash immediately with soap and water. If acid enters eye, immediately flood eye with running cold water for at least 15 minutes and get medical attention immediately.
- g) NEVER SMOKE or allow a spark or flame in vicinity of battery.
- h) Be extra cautious to reduce risk of dropping metal tool onto battery. It might spark or short circuit battery or other electrical part that may cause explosion.
- i) Remove personal metal items such as rings, bracelets and watches when working with a lead-acid battery. A lead-acid battery can produce a short circuit current high enough to weld a ring or the like to metal, causing a severe burn.
- j) Remove all sources of power, photovoltaic and battery before servicing or installing.

4. CHARGER LOCATION & INSTALLATION

- a) This unit is designed to charge 12 volt (6 cell) flooded or sealed type lead-acid chemistry batteries within the range of 20 to 2,000 amp-hours. Follow battery manufacturers charging recommendations when considering this unit for use with other battery chemistry.
- b) This unit employs components that tend to produce arcs or sparks. NEVER install in battery compartment or in the presence of explosive gases.
- c) This unit must be installed and wired in accordance with National Electrical Code, ANSI/NFPA 70.
- d) Over current protection for the battery must be provided externally. To reduce the risk of fire, connect to a circuit provided with 40 amperes maximum branch-circuit over current protection in accordance with National Electrical Code, ANSI/NFPA 70.
- e) Insure that charge parameters are properly configured for the battery being charged as recommended by the battery manufacturer.
- f) This unit is not water tight. Do not expose to rain, snow or excessive moisture.
- g) Insure all terminating connections are clean and tight. Tighten Battery and PV compression terminals to 4.4 in-lb (0.5 nm) and battery temperature sensor compression terminals to 2.1 in-lb (0.24 nm).
- h) Do not connect to a PV array capable of producing greater than 27 amps of short circuit current I_{SC} , or 24 volts open circuit voltage V_{OC} @ STC.

5. PREPARING TO CHARGE

- a) Never charge a frozen battery.
- b) Be sure battery is mounted in a well ventilated compartment.
- c) Add distilled water in each cell of a lead-acid battery until battery acid reaches level specified by battery manufacturer.

PRODUCT DESCRIPTION

The Sun Charger 30 is a 30 amp 12 volt *Pulse Width Modulated* (PWM) photovoltaic (PV) battery charge controller. The SC30's sophisticated 3-stage plus equalization charge control system improves battery performance and life while minimizing battery maintenance. The unit is electronically protected against voltage transients, over temperature, over current, short circuit, swapped battery & PV, and reverse battery & PV polarity. A current limit feature minimizes the likelihood of overload by limiting output current to 30 amps maximum during periods of unusually high PV power production. A very low power LED display is provided to monitor battery voltage and PV charge current. The display system also includes a resettable amp-hour counter which computes total PV amp-hours produced. The SC30-LVD version of the product can also drive an external power relay to provide Low Voltage Disconnect (LVD) load control and lighting control functionality. The SC30-LVD is available by special order.

PART NUMBERS AND OPTIONS

- SC30.....Sun Charger 30 solar charge controller
- SC30-LVD.....SC30 with Load & Lighting control drive signal
- 930-0022-20Optional battery temperature sensor
- 720-0011-01Optional wall mounting box, black powder coated

OPERATION

Basic charge control operations are fully automatic and require no operator intervention. When sufficient PV power is available the SC30 will switch to a Charge ON state and begin charging the battery. The particular charge mode the SC30 will operate in will vary depending on the needs of the battery and 12 volt electrical system, and available PV charge current. When insufficient PV current is available to charge the battery the SC30 will switch to a Charge Off state. At night when the SC30 is in a Charge Off state the PV array is disconnected from the battery to prevent unwanted current drain. There is a 5 second turn-on delay, and a 30 second turn-off delay.



➤ The SC30 operates on battery power, not PV power. Insure that voltage on the battery terminals of the SC30 is always the same as actual battery voltage within a few 10^{ths} of a volt for proper operation. A battery must be connected with a minimum voltage of 9 volts for the unit to operate. Note that the front panel serves as a heatsink for power control devices and may become quite warm during normal operation.



➤ **CAUTION:** Do not disconnect the battery while the SC30 is in a Charge ON state. A healthy battery is a key component of PWM charge voltage control and provides charge voltage filtering. Sudden removal of the battery while the SC30 is charging will produce voltage spikes at the SC30's battery terminals which may damage 12 volt appliances still connected to the SC30.

IF THE BATTERY MUST BE DISCONNECTED, REMOVE PV POWER FIRST.

CHARGE STATUS INDICATION

Present charge status of the SC30 is indicated using two charge status LED's, Absorption & Float. If net battery charge current is greater than about 3 to 5 amps per 100 amp-hours of battery capacity the charge status indicator can provide a rough indication of battery state of charge.

CHARGE STATUS

CHARGE STATUS LED'S	CHARGE MODE	APPROXIMATE CHARGE LEVEL
ABSORPTION & FLOAT OFF	CHARGE OFF	_____
ABSORPTION & FLOAT ON	BULK	<70% FULL
ABSORPTION ON – FLOAT OFF	ABSORPTION	70% - 95% FULL
ABSORPTION OFF – FLOAT ON	FLOAT	FULLY CHARGED
ABSORPTION & FLOAT ALTERNATELY BLINKING	EQUALIZE	_____

TABLE 1

DIGITAL DISPLAY

When the SC30 first boots and completes self-test, the VOLT/AMP display mode is active. This mode displays Battery Voltage continuously if the SC30 is in a Charge Off state, or alternates between Battery Voltage & Output Charge Current if the SC30 is in a Charge On state. The AMPS indicator in the upper left of the display will be on whenever current is displayed. To provide good readability during the day yet minimize the likelihood of the display being objectionably bright at night an automatic night time dimming feature is provided which dims the display when the SC30 is in a Charge Off state. Other display modes may be selected using the Display Select push-button. Each brief press of Display Select selects the next display mode as shown on the front panel graphic of Figure 1. VOLT shows Battery Voltage, AMP shows Output Charge Current, and AMP-HRS shows total PV Amp-Hours produced since the amp-hour counter was last cleared. One more brief press after AMP-HRS turns the display off completely. Each brief press of Display Select moves to the next display mode in a continuous loop as shown on the front panel graphic. Note that the Amp-Hours are shown in whole numbers without a decimal point.

SOLAR CHARGE AMP-HOUR COUNTER

The battery essentially serves as a “storage tank”, with the battery storing electrical energy in units referred to as amp-hours. Amp-hours are computed by multiplying *current in amps X time in hours*. For example 20 amp-hours may be a current of 10 amps flowing for 2 hours, or may be 1 amp flowing for 20 hours. The battery receives and stores amp-hours when being charged, and then delivers those stored amp-hours when being discharged. As a broad approximation typical lead-acid batteries including GEL and AGM are about 95% efficient in absorbing charge amp-hours. The amp-hour counter displays total solar charge amp-hours accumulated since the last time the counter was cleared up to a maximum count of 999 amp-hours. Amp-hour production varies widely with operating conditions, but as a very broad brush approximation 100 watts of PV modules can deliver up to a maximum of about 30 amp-hours per day. Any partial shading, lower sun intensity, shorter days, or time spent in Absorption or Float will decrease amp-hours produced. The present amp-hour count may be cleared by pressing Display Select for 5 seconds while viewing amp-hours on the display.

BATTERY LEVEL GRAPHIC

The SC30 provides a battery level graphic on the front panel which indicates approximate battery level versus battery voltage. Generally a higher voltage is better than a lower voltage. Note that the graphic does not illuminate. A battery that is being charged will typically range in voltage from about 12.5

volts after charge commences, to perhaps 14.0 volts or greater when the battery is highly charged. Once charge stops and the battery begins discharging and delivering power to a load it is normal for battery voltage to drop. A battery under a light load of about 1 amp per 100 amp-hours of battery capacity may range between about 12.5 volts when the battery is full, down to perhaps 12.0 volts when the battery is about 50% discharged. Battery voltage during discharge will tend to be higher under light load and lower under a heavier load. Do not think of these voltage values as absolutes but rather as a broad brush indication of battery level. Voltage at a particular state of charge will vary with battery size, age, construction, temperature, and with the level of charge or discharge current. Most battery manufacturers recommend not discharging below about 50% DOD (depth of discharge) to promote improved battery performance and life. Avoid allowing battery voltage to drop below about 11.5 volts, and NEVER allow battery voltage to drop below 10.0 volts.

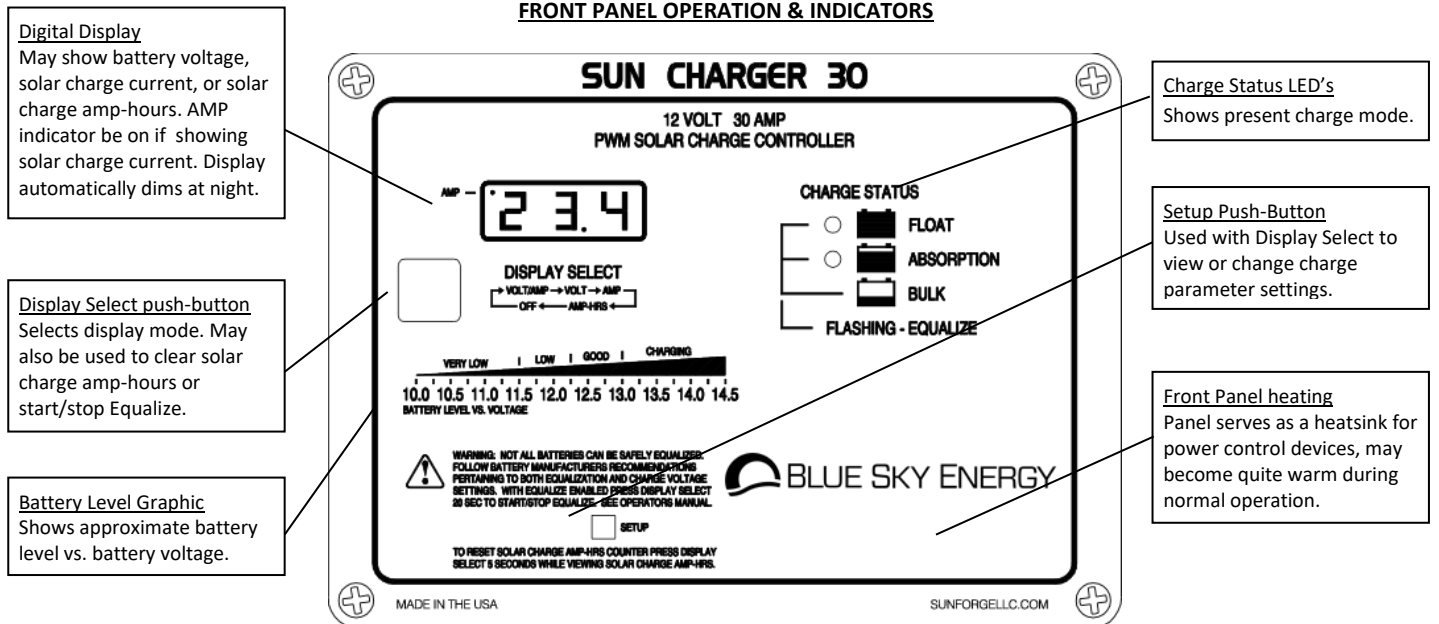

FIGURE 1

3-STAGE CHARGE CONTROL

The SC30 is factory configured for a 3-stage charging process, Bulk, Absorption and Float, which is fully automatic and requires no operator intervention. The 3-stage charge process applies a somewhat higher Absorption charge voltage to charge the battery quickly and safely. Once the battery is fully charged a somewhat lower Float voltage is applied to maintain the battery in a fully charged state without excessive water loss.



➤ The charge control system always starts in Absorption and will return to Absorption upon exiting Current Limit or Equalization. Following a 20 second delay in Absorption the SC30 may move on to other charge modes based on battery and system needs.

Bulk Charge

The SC30 will switch to Bulk charge when battery voltage remains below the present charge voltage setpoint. During Bulk the SC30 delivers as much charge current as possible to rapidly recharge the battery. During Bulk it is a combination of battery size, state of charge and available charge current that determine battery voltage, not the SC30.

Absorption Charge

When the battery recovers sufficient charge for battery voltage to rise to the Absorption Charge Voltage setpoint (factory set to 14.4V), charge current is reduced as necessary to hold the battery at the Absorption Voltage. The SC30 remains in Absorption until the battery is fully charged as determined by the SC30 remaining continuously in Absorption for the Absorption Charge Time period (factory set to 2 hours). The SC30 will return to Bulk should battery voltage remain below the Absorption Voltage setpoint for more than 20 seconds.

Float Charge

Once the battery is fully charged a somewhat lower Float Voltage (factory set to 13.2V) is applied to maintain the battery in a fully charged state without excessive water loss. The SC30 will return to Absorption should battery voltage remain below the Float Voltage setpoint for more than 20 seconds.

2-STAGE CHARGE CONTROL

Certain battery types or system configurations may require 2-stage Bulk/Absorption charge control. The SC30 can be configured for 2-stage charge control by setting the Float Charge Voltage to OFF (NO Float).

30 AMP CURRENT LIMIT

Should transient conditions be present where the PV modules are able to produce more than 30 amps of output current, the SC30 will automatically limit average output current to 30 amps. It is possible for output current to briefly exceed 30 amps as the current limit control system responds to sudden increases in PV current. Note that when current drops and the SC30 exits current limit it will first enter Absorption (for 20 seconds) on its way back to Bulk even though battery voltage may be below the Absorption Charge Voltage setpoint.



➤ **WARNING:** Current limit should be thought of as transient PV over current protection and not a normal mode of operation. If the SC30 enters current limit and/or delivers 30 amps of output on a regular basis it is possible that excessive PV power is connected. Confirm that the PV modules do not exceed ratings shown in the Selecting PV Modules section.

OPTIONAL TEMPERATURE COMPENSATION

The charge voltage required by batteries changes with battery temperature. Temperature compensation of charge voltage enhances battery performance and life while decreasing battery maintenance. Temperature compensation of charge voltage can be provided using the optional battery temperature sensor (BSE p/n 930-0022-20). The default compensation factor of $-30\text{mV}/^\circ\text{C}$ is typically appropriate for most lead-acid chemistry batteries including GEL and AGM. If a proper temperature sensor signal is not detected the SC30 will operate as if battery temperature is 25°C .

FACTORY DEFAULT CHARGE VOLTAGE SETPOINTS -VS.- BATTERY TEMPERATURE

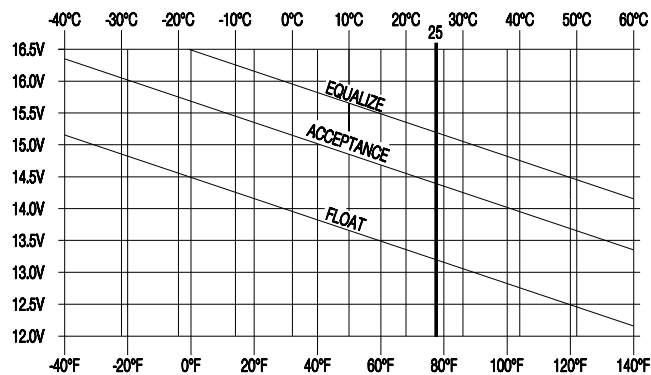

FIGURE 2

EQUALIZATION



➤ **WARNING:** Not all batteries can be safely equalized. Equalization should be performed only on vented liquid electrolyte lead-acid batteries. Always follow battery manufacturers recommendations pertaining to equalization. Equalization applies a relatively high charge voltage producing significant battery gassing. Prior to performing equalization disconnect equipment that cannot tolerate the high equalization voltage which is temperature compensated as shown above.

Equalization is essentially a controlled overcharge which applies a relatively high charge voltage to bring all battery cells up to the same specific gravity and state of charge. The SC30 may be configured to perform either an automatic equalization on periodic basis, or a manually initiated equalization. Since sealed batteries should not be equalized the factory default settings have Equalize Enable set to OFF to completely disable automatic or manual equalization. Equalization may be enabled by setting Equalize Enable to ON as described in the Charge Parameter Settings section. When an equalization cycle is being performed the Float and Absorption charge status LED's will alternately blink. With equalize enabled the SC30 will perform an automatic equalization at the factory default settings of 15.2V for 2 hours every 30 days which is typically suitable for most flooded lead-acid batteries. When set for automatic equalization the cycle will begin when the set number of days since the last equalization has elapsed, and the charge control system has switched to Float. When set for manual equalization (Equalize days set to 00) an automatic equalization will not occur. Whether set for automatic or manual the process may be started or stopped manually by pressing the Display Select push-button for 20 seconds. Once equalization has started the equalize timer will not count down unless battery voltage is at the equalize voltage setpoint which is temperature compensated. Therefore obtaining a proper 2 hour equalization will require longer than 2 hours to complete depending on available charge current. Note that at least 3.5 amps of net charge current per 100 amp-hours of battery capacity is typically required to properly equalize a battery. If equalization does not complete during the charging day it will resume where it left off the next charging day, but will automatically cancel if unable to complete within 24 hours. The equalize day counter is reset whenever an equalization cycle is started.

MAXIMUM SETPOINT VOLTAGE LIMIT

The maximum setpoint voltage limit is not a charge voltage setting but rather places a maximum limit or ceiling on the charge voltage setpoint actually used by the SC30 in all charge modes. Regardless of setpoint values entered by the user or how setpoints may adjust due to temperature compensation the SC30 will not use a charge voltage setpoint greater than the maximum setpoint voltage limit factory set to 15.5V. The purpose of the maximum setpoint voltage limit is to prevent charge voltage from getting so high that Inverters or other equipment shut down due to excess voltage. Note that actual battery voltage may briefly exceed this value by perhaps 0.1 – 0.2V as the voltage control system responds to sudden changes in loads or available PV current.

PULSE WIDTH MODULATION

The SC30 uses Pulse Width Modulation (PWM) charge voltage control. When battery voltage is below the present charge voltage setpoint the PV module is continuously connected to the battery to deliver maximum charge current. Once the battery recovers sufficient charge for voltage to rise to the charge voltage setpoint, charge current must be reduced to properly regulate battery voltage or voltage would continue to climb. When a reduction in charge current is necessary the PWM control system reduces average current delivery by rapidly connecting and disconnecting the PV module at a fixed frequency of 50Hz. The rapid on/off switching of PV charge current may produce a slight 50Hz buzzing sound which may come from the SC30 or user

installed wiring. If only 80% of the available PV current is required to hold battery voltage at setpoint the PV is connected (or turned on) for 80% of the time and remains off for 20% of the time. The control system varies or “modulates” the ON time “pulse width” percentage as necessary to control battery voltage, hence the term *Pulse Width Modulation*. Because charge current is either full on or full off during PWM control the battery provides a very important voltage filtering function in a PWM control system due to its very stiff resistance to changing voltage quickly. Therefore a battery must always be connected to provide proper voltage control.

PANEL TEMPERATURE AND THERMAL PROTECTION

Internal power control devices use the front panel as a heatsink. It is normal for the front panel to become quite warm to the touch when the SC30 is operating at high power. When mounted to a vertical surface with good ventilation, the SC30 can deliver full output in an ambient temperature of up to 45°C (113°F). If an over temperature condition exists, the SC30 will simply cycle on and off to keep internal temperature within acceptable limits.

LOAD CONTROL AND LIGHTING CONTROL (SC30-LVD version only)

The SC30-LVD version of the product provides a low current relay drive output to provide either Low Voltage Disconnect (LVD) load control, or lighting control with LVD. The load control output is omitted in the standard SC30 version of the product. The SC30-LVD drives the external relay and the external relay switches power to the load. The relay drive terminal is overload and short circuit protected and can sink 50mA if the SC30-LVD front panel is at its maximum operating temperature of 70°C. In a typical lighting application where panel temperature is below 50°C when lighting control switching occurs the relay drive can sink 80mA. Default settings provide LVD operation with ON at $V_{BAT} \geq 12.6V$, and OFF at $V_{BAT} \leq 11.5V$. The ON/OFF condition must be valid for 20 seconds before switching will occur. If the higher/lower values are reversed the output control logic is inverted. The SC30-LVD can also provide lighting control with two separate lighting timers. Variable time settings are available to turn lighting ON after Dusk (Post-Dusk timer) and/or ON before Dawn (Pre-Dawn timer). If both timers are set to OFF (factory default), the lighting control feature is disabled and the output provides LVD operation only. If either the Post-Dusk or Pre-Dawn timers are set to a time value the lighting control feature is enabled. When lighting control is enabled the relay drive output is controlled by both the LVD control function and the lighting control function such that whichever function wants the output OFF prevails. Dusk or night time begins when the charge control system turns OFF which occurs when PV module current drops below $\approx 50mA$ at battery voltage. Dawn or day time begins when the charge control system turns ON which occurs when PV module current rises to $\approx 100mA$ at battery voltage. If the Post-Dusk timer was set to 1.0 hour and the Pre-Dawn timer was set to 2.0 hours, lights would turn ON at Dusk, remain ON for one hour, and then turn OFF. Two hours before Dawn the lights would again turn ON and remain ON until Dawn. For full Dusk to Dawn lighting set the Post-Dusk timer to 20 hours. When the SC30 first receives battery power it does not know when Dawn is expected to occur. As a result Pre-Dawn control does not operate for the first night. Once a night time period of 4 hours or more is detected this night time period is stored and Pre-Dawn control will operate. Each subsequent night time period greater than 4 hours is added to a filtered average of night time so that the predicted night time period automatically adjusts with changing seasons.

INSTALLATION



➤ **WARNING:** The SC30 is designed for use with 12 volt DC electrical systems only. Read, understand and follow the Important Safety Instructions in the beginning of this manual before proceeding. This unit must be installed and wired in accordance with National Electrical Code, ANSI/NFPA 70. Over current protection must be provided externally. To reduce the risk of fire, connect to a circuit provided with 40 amp maximum branch-circuit over current protection in accordance with National Electrical Code, ANSI/NFPA 70. Do not connect a PV array capable of delivering greater than 27 amps short circuit current (I_{sc}) or 24 volts open circuit voltage (V_{oc}) at STC. Do not connect BAT- & PV- together external to the unit. To reduce risk of electric shock or product damage, remove all power before installing or servicing. Figure 3 shows generalized connections only is not intended to show all wiring, circuit protection and safety requirements for a photovoltaic electrical system.



➤ **CAUTION:** The SC30 is protected against reverse battery polarity, short duration reverse PV polarity, and swapped PV and battery connections. The SC30 will be damaged by long duration reverse PV, reverse battery to the PV terminals, and voltage in excess of 30 volts on the battery or PV terminals.. Damage resulting from these user induced faults voids the limited warranty.

CHARGE PARAMETER SETTINGS

The SC30 contains various charge parameter settings all of which are preconfigured at the factory to the default settings shown below. Most installations require no changes to these settings which are typically suitable for most flooded, GEL and AGM lead-acid chemistry batteries.



➤ **WARNING:** If charge parameter settings are changed, confirm that the new settings comply with the battery manufacturers recommendations. DO NOT enable equalization for sealed lead-acid batteries such as GEL and AGM.

As Shipped Factory Default Settings

- | | | | |
|--|-----------|---|----------------|
| • Charge mode | 3-stage | • Equalize enable | Off (disabled) |
| • Absorption voltage | 14.4V | • Equalize time | 2.0 hours |
| • Absorption time | 2.0 hours | • Equalize voltage | 15.2V |
| • Float voltage | 13.2V | • Auto equalize days | 30 days |
| • Maximum setpoint voltage limit | 15.5V | • Temperature compensation factor | -30mV/°C |
| • LVD on voltage* | 12.6V | • PostDusk lighting timer * | Off (disabled) |
| • LVD off voltage* | 11.5V | • PreDawn lighting timer * | Off (disabled) |

(*) Applies to SC30-LVD version only

Restoring As Shipped Factory Default Settings

1. Remove both PV and battery power.
2. Apply battery power while pressing & holding the Setup push-button.
3. Following display self-test, confirm display shows software revision (e.g., r1.4) & Charge Status LED's remain on while Setup is held.
4. After at least 5 seconds, release Setup.
5. Confirm display resumes normal operation.
6. The SC30 is now set to as shipped factory defaults.

Changing Charge Parameter Settings

SC30 charge parameter settings may be viewed or changed at any time using a combination of the Setup and Display Select push-buttons. There are two modes of setup operation, **Viewing** a setting and **Changing** a setting. Basic operation is to go from Normal Operation to Viewing Mode, Viewing Mode to Changing Mode, and then from Changing mode back to Viewing mode, and Viewing Mode back to Normal Operation. All settings are stored in Flash memory and are retained if power is lost.

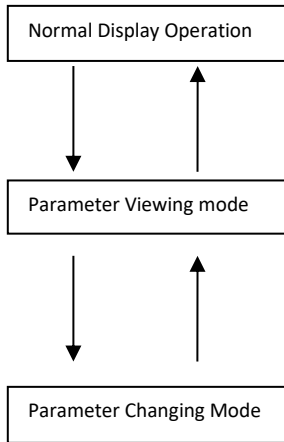

Viewing a setting
 To enter the Viewing Mode press Setup 5 seconds and release when **AbS** appears in the display. The first parameter to be shown is the *Absorption Charge Voltage* setting. The display will alternate between **AbS** and **14.4** to show the present *Absorption Charge Voltage* setting is 14.4V.
 A brief press of Setup within 5 seconds will move to the next setting shown in Table 2, *Absorption Charge Time* where the display will now alternate between **Abt** and **2.0** to show the present *Absorption Charge Time* setting is 2.0 hours. Remaining settings may be viewed by repeatedly pressing Setup to move to the desired setting. To exit Viewing Mode and return to normal operation, do not press Setup for 5 seconds.

Changing a setting
 To enter the Changing Mode, first enter the Viewing Mode for the setting to be changed. While in Viewing Mode for that setting, press Setup 5 seconds to enter the Changing Mode for that setting. The present setting value will begin blink rapidly indicating that you have entered the parameter changing mode for that setting. Use Display Select to scroll through the available values until the desired value is reached. With the desired new value blinking in the display press Setup 5 seconds to save the new setting. Once the new setting is saved the display will revert back to the Viewing Mode showing the new saved value for that setting.
 If neither Setup or Display Select is pressed within 5 seconds while in the Changing Mode, the change request is abandoned and the display reverts back to Viewing Mode without changing the setting.

CHARGE PARAMETER SETTINGS

Parameter viewing mode toggles between setting text and value of that setting		Setting Range	Setting Steps	Description
Setting Text	Default Setting			
AbS	14.4	12.0V – 17.0V	0.1V	Absorption charge voltage
Abt	2.0	0.0 – 10.0 hrs	0.5 hrs	Absorption charge time
Flt	13.2	12.0V – 17.0V	0.1V	Float charge voltage Set to oFF (one step below 12.0) for 2-stage charge
EqU	15.2	12.0V – 17.0V	0.1V	Equalize charge voltage
Eqt	2.0	0.5 – 10.0hrs	0.5 hrs	Equalize charge time
Eqd	30	10 – 400	5 days	Auto equalize days. Setting of zero (00) selects manual equalization.
EqE	oFF	on or oFF		Master equalize enable/disable Set to on to enable equalization
uPr	15.5	12.0V – 17.0V	0.1V	Maximum setpoint voltage limit
btc	500 (–5.00mV/°C/cell)	000 – 800 (–0.00 to –8.00 mV/°C/cell)	10 (0.10mV/°C/cell)	Battery temperature compensation factor (decimal point missing in display such that 500 = –5.00mV/°C/cell. Default provides overall factor of –30mV/°C for 6 cell 12V battery)
-- The following load and lighting control settings are present in the SC30-LVD only and are omitted in the standard SC30 --				
Lon	12.6V	5.0V – 17.0V	0.1V	Load control LVD on threshold
LoF	11.5V	5.0V – 17.0V	0.1V	Load control LVD off threshold
PSt	oFF	0.5 – 20.0 hrs	0.5 hrs	PostDusk lighting timer. Set to oFF (one step below 0.5) to disable.
PrE	oFF	0.5 – 20.0 hrs	0.5 hrs	PreDawn lighting timer. Set to oFF (one step below 0.5) to disable.

TABLE 2

SELECTING PV MODULES

The SC30 is designed to work with 12V PV modules only. Higher voltage modules or input power sources other than PV modules will damage the SC30 in a manner which voids the limited warranty. Voltage, current and power produced by PV modules vary widely with operating conditions. As a result a set of test conditions referred to as *Standard Test Conditions* or STC are used to rate modules in a meaningful manner and the manufacturer’s published STC ratings that must be used when selecting PV modules. STC ratings are not maximum or optimal ratings. Operating conditions can be present where PV voltage and current may exceed published STC ratings which is why PV module voltage and current must be limited to the values shown below. While conditions may be present where V_{OC} , I_{SC} & I_{MP} exceed STC ratings, in real world conditions actual charge current typically seen may only be about 75 – 80% of I_{MP} at STC.

Key PV module specifications:

- P_{MAX} Maximum power in watts ($P_{MAX} = V_{MP} \times I_{MP}$)
- V_{OC} Voltage with module open circuit (typically $\approx 20 - 23V$ for 12V nominal modules)
- V_{MP} Voltage where module produces Maximum Power (typically $\approx 17 - 18V$ for 12V nominal modules)
- I_{MP} Current where module produces Maximum Power
- I_{SC} Current with module Short Circuit

Select PV modules that DO NOT exceed the maximum ratings below and preferably deliver at least 3 amps I_{MP} per 100 amp-hours of battery capacity.

Maximum PV Power @ STC	Maximum PV I_{sc} @ STC	Maximum PV V_{oc} @ STC	Recommended range of V_{MP} at STC
			Nominal 12V PV
450W	27.0A	24.0V	16.0 – 19.0V

BATTERY AND PV WIRING

A desirable installation will produce a total system wiring voltage drop of 3% or less. The lengths shown in Table 3 are one way from the PV modules to the battery with the SC30 located along the path. Wire length can be increased inversely proportional to actual current. If current was reduced by 1/2 wire lengths could be doubled and still provide the same 3% voltage drop.

MAXIMUM CONDUCTOR PAIR LENGTH – 3% VOLTAGE DROP

WIRE GAUGE AWG	12 VOLT SYSTEM @27A FEET / METERS
12 AWG	4.8 / 1.5
10 AWG	7.6 / 2.3
8 AWG	12.0 / 3.7
6 AWG	19.2 / 5.9
4 AWG	30.3 / 9.2
2 AWG	48.3 / 14.7

TABLE 3



➤ **CAUTION:** Battery and PV compression terminals will accept #16 – #10 AWG wire and are to be tightened to 4.4 in-lb (0.50 nm). Temperature Sensor and Load Drive compression terminals accept #26–16 AWG wire and are to be tightened to 2.1 in-lb (0.24 nm). Take care to route wires in a manner that does not place undue strain on the SC30’s compression terminal blocks.

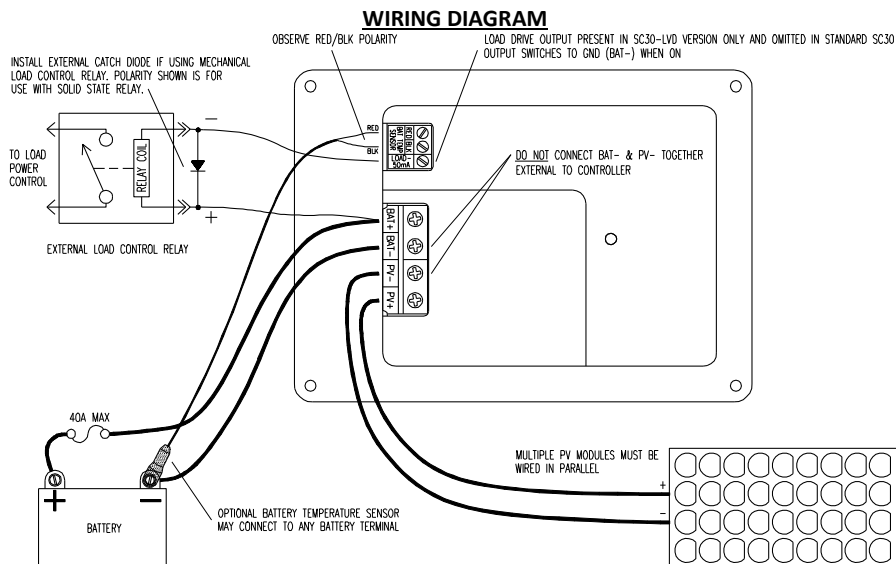

FIGURE 3

OPTIONAL BATTERY TEMPERATURE SENSOR

Install the optional battery temperature sensor as shown in Figure 3. The temperature sensor will be automatically detected by the SC30.



➤ **WARNING:** Use only BSE temperature sensor p/n 930-0022-20. Other temperature sensors or electrical connections to the temperature sensor terminals may damage the SC30, void the limited warranty, and may cause charge voltage to become uncontrolled. Note that temperature sensor wires are polarized RED/BLK and the sensor will not function if installed reverse polarity. The temperature sensor lug may connect to any battery terminal.

BATTERY & PV POWER CONNECT / DISCONNECT ORDER



➤ **CAUTION:** When applying power to the SC30, battery power should be connected first followed by PV power. Disconnect PV power first when removing power. DO NOT disconnect the battery while the SC30 is in a Charge ON state with PV power connected. A healthy battery is a key component of the PWM charge voltage control system and provides a very important charge voltage filtering function. Removal of the battery while the SC30 is charging will produce voltage spikes at the SC30's battery terminals which may damage 12V appliances still connected to the output SC30.

IF THE BATTERY MUST BE DISCONNECTED, REMOVE PV POWER FIRST.

Connecting the Battery

Before attaching battery wires to the SC30 confirm proper voltage and polarity. With battery power attached the SC30 should boot and self-test. All display segments and LED's will briefly illuminate during self-test, followed by a brief display of the software revision. Following self-test battery voltage will be displayed although the display will be dim due to the night time dimming function. If the display does not turn on check voltage on the SC30's battery terminals. Voltage should be the same as present on the batteries, of the proper polarity, and greater than 9 volts for the SC30 to operate.

Connecting PV Modules

Before attaching PV wires to the SC30 confirm proper voltage and polarity. Measure PV module voltage with PV modules in the sun and disconnected from the SC30. Confirm open circuit voltage is within the range of approximately 18 – 23 volts, and of the proper polarity. If PV open circuit voltage is outside this range confirm proper PV module selection and wiring. Attaching PV power should cause the SC30 to switch to Charge ON state.



➤ **CAUTION:** PV voltage exceeding 30 volts will damage the SC30 and void the limited warranty. The SC30 is protected against limited duration reverse PV polarity. If available PV current is high and reverse PV polarity duration is long, damage may result which voids the limited warranty. Immediately following PV power connection confirm that the SC30 display continues to operate normally and the unit switches to a Charge On state as expected. **Reverse PV connection will cause the display to continuously show the self-test indication of all display segments and LED's on, and the front panel may get hot quickly. Should this occur immediately remove PV power and correct the fault.**

MOUNTING



➤ **CAUTION:** Mount the SC30 vertically to promote air flow and cooling, do not enclose in a confined space and avoid mounting in direct sunlight. The SC30 is not watertight and must be protected from rain, snow and excessive moisture. Corrosion resulting from liquid water or excessive moisture voids the limited warranty. An optional black powder coated deluxe mounting box available as BSE p/n 720-0011-01. The optional mounting box is the same X,Y dimension as the SC30 front panel and 2.75" (7cm) deep.

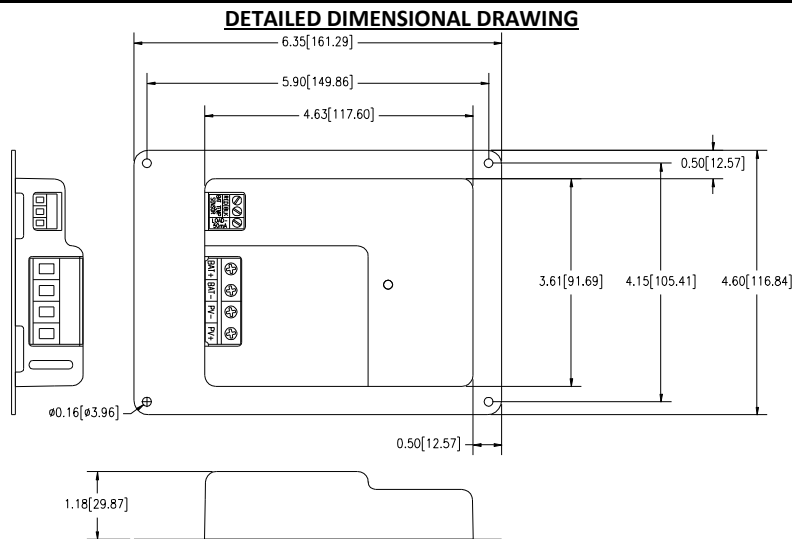

FIGURE 4

TROUBLESHOOTING GUIDE

SYMPTOM	PROBABLE CAUSE	ITEMS TO EXAMINE OR CORRECT
Completely dead, display blank.	No battery power. Display mode set to OFF.	Battery disconnected, overly discharged, or connected reverse polarity. Battery powers SC30, not PV. Voltage present on the SC30's battery terminals must be the same as actual battery voltage within a few 10 ^{ths} and at least 9 volts. Press Display Select to select display mode other than OFF.
Unit will not switch to Charge ON state.	No battery power. PV disconnected or low in voltage. PV reverse polarity. Microprocessor lockup. Over temperature shutdown.	Battery disconnected, overly discharged, or connected reverse polarity. Battery powers SC30, not PV. Voltage present on the SC30's battery terminals must be the same as actual battery voltage within a few 10 ^{ths} and at least 9 volts. PV voltage when connected to the SC30 must be at least 0.3V greater than battery voltage for SC30 to switch to Charge On State. Reverse PV will heat front panel & force all display segments & LED's ON. Momentarily remove all power (battery & PV) to re-boot. Normal operation will resume when the SC30 cools down.
Unit will not stay in a Charge ON state.	Low and changing sun intensity. PV- connected to BAT- external to controller.	Normal operation. PV- & BAT- must be separate for proper operation. External connection prevents proper operation of current measurement system.
Charge status indicator ON but no output charge current.	Battery voltage greater than charge voltage setpoint. Battery voltage too low. Poor connection to the battery. PV- connected to BAT- external to controller.	Normal operation. Output is off due to high battery voltage which may be caused by other charging systems, or immediately following a switch to Float before battery voltage dropped and settled. Battery voltage must be at least 9 volts for the SC30 to operate. Voltage present on the SC30's battery terminals must be the same as actual battery voltage within a few 10 ^{ths} . Examine connections and fuse & fuse holder. PV- & BAT- must be separate for proper operation. External connection prevents proper operation of current measurement system.
Charge OFF at high ambient temperature.	System temporarily shuts down due to high internal temperature.	Improve ventilation or reduce PV power.
Charge current is lower than expected.	Battery is highly charged. User expectations too high. Worn out or very dissimilar PV modules Low sun intensity PV- connected to BAT- external to controller.	Normal operation. Current is intentionally reduced in Absorption & Float to control battery voltage at setpoint. Maximum available charge current will only be seen when the SC30 is in Bulk. Even though the PV's may be in full sun, clean, and with zero shading it is common to only see about 75 – 80% of total PV I _{MP} . Note that the smallest amount of shade can cause a large reduction in charge current. Replace, or use as is. Atmospheric haze, PV's dirty or shaded, sun low on horizon, etc. PV- & BAT- must be separate for proper operation. External connection prevents proper operation of current measurement system.
System appears to operate OK, but will not switch between Bulk, Absorption & Float.	Not set for 3-stage charge. Will not switch out of Bulk and into Absorption or Float. Will not switch from Absorption to Float.	Confirm Float voltage setpoint is not set to OFF. Available net charge current cannot bring battery voltage up to the desired charge voltage setpoint. Battery may be too large, PV power too low, and/or loads too high. PV's should produce at least 3 amps per 100 amp-hours of battery –and– daily PV amp-hours produced must be greater than daily load amp-hours consumed. Battery not fully charged. Unit will not switch to Float until SC30 remains in Absorption continuously for the Absorption Charge Time period. Periodic load pulls battery voltage low causing SC30 to re-enter Bulk resetting the Absorption Charge Timer. Consider using a shorter Absorption Charge Time setting.
Temperature compensation of charge voltage does not work.	Temperature sensor missing. Wrong temperature sensor. Temperature sensor failed or installed reverse polarity.	Install battery temperature sensor BSE p/n 930-0022-20. Use only BSE battery temperature sensor p/n 930-0022-20. If sensor is open, short, reverse polarity or missing SC30 will operate as if battery temperature is 25°C. Proper sensor voltage when excited by the SC30 will read approximately 2.98V at 25°C, changing at +10mV/°C.
LVD Load control not working	Output may have shut off due to low battery charge	Load will shut off if battery voltage drops below OFF threshold (11.5V). Once shut off, the load will not come back on until battery voltage is above ON threshold (12.6V).

SYMPTOM	PROBABLE CAUSE	ITEMS TO EXAMINE OR CORRECT
LVD Load control not working	ON/OFF thresholds set incorrectly or external relay wired incorrectly Lighting control enabled	Correct ON/OFF threshold settings or external relay wiring. Load will shut off if lighting control enabled and SC30-LVD is in Charge On state.
Dusk-to-Dawn feature, lights will not turn ON or remain ON	Output may have shut off due to low battery charge Charge control system ON Timers set incorrectly Valid night time period not seen	Load will shut off if battery voltage drops below OFF threshold (11.5V). Once shut off, the load will not come back on until battery voltage is above ON threshold (12.6V). Lights will not turn on if SC30-LVD is in Charge On state. Check time settings PostDusk or PreDawn timer. Pre-Dawn lighting will not operate until a valid night time period of ≥4 hours detected.
Dusk-to-Dawn feature, lights will not turn OFF	Timers set incorrectly Charge control does not turn ON	Post-Dusk or Pre-dawn timer must be set to time value to enable lighting control. Check charge control system related items.

Specifications:	SC30 @12V	SC30-LVD @12V
Maximum PV Power:	450W with 36-cell PV panel ^(*)	
Rated Battery (Output) Current:	30A with 36-cell PV panel ^(*)	
Power Consumption:	0.17W (typical standby)	
Recommended Max Panel Voc at STC:	24V (Max Panel Input 30V)	
Charge Profile:	Multi-Stage plus Automatic Equalization	
Absorption Voltage:	14.4V (Programmable) ⁽¹⁾	
Float Voltage:	13.2V (Programmable) ⁽¹⁾	
Equalization Voltage (if enabled):	15.2V (Programmable) ⁽¹⁾	
Auxiliary Output:	--	50mA drive signal with LVD ⁽¹⁾
Load (LVD) Disconnect/Reconnect Voltage:	--	11.5V/12.6V ⁽¹⁾
Display:	Yes	
Temperature Compensation (by optional Battery Temp. Sensor):	-5.00mV/°C/cell correct factor (Range 0.00 to -8.00mV/°C/cell) ⁽¹⁾	
Operating Temperature:	-40°C – 45°C	
Environmental Protection:	IP10	
Weight:	0.45 lb. (205 g)	
Dimensions:	4.6 x 6.35 x 1.18" (11.8 x 16.1 x 3.0 cm)	

^(*) 36-cell panels are typically referred to as "12V panels" providing Vmp/Voc of ~18V/22V at STC, 60-cell panels refers to "20V panels" (Vmp/Voc ~30V/37V), 72-cell panels refers to "24V panels" (Vmp/Voc ~36V/44V) - ⁽¹⁾ Factory default, programmable via digital display.

NB. As a part of our continuous improvement process specifications are subject to change without prior notice.

FIVE YEAR LIMITED WARRANTY

Blue Sky Energy, Inc. (hereinafter BSE), hereby warrants to the original consumer purchaser, that the product or any part thereof shall be free from defects due to defective workmanship or materials for a period of five (5) years subject to the conditions set forth below.

1. This limited warranty is extended to the original consumer purchaser of the product, and is not extended to any other party.
2. The limited warranty period commences on the date the product is sold to the original consumer purchaser. A copy of the original purchase receipt identifying purchaser and date of purchase, must accompany the product to obtain warranty repairs.
3. This limited warranty does not apply to, and future warranty shall become void, for any product or part thereof damaged by; a) alteration, disassembly or application of a foreign substance, b) repair or service not rendered by a BSE authorized repair facility, c) accident or abuse, d) corrosion, e) lightning or other act of God, f) operation or installation contrary to instructions pertaining to the product, or g) cosmetic aging.
4. If BSE's examination of the product determines that the product is not defective the consumer shall be charged a test and evaluation fee of \$20 and be responsible for all transportation costs and insurance related to returning the product to the consumer. The consumer is ultimately responsible for proper installation and operation of the product and BSE's prior troubleshooting assistance shall not serve as a waiver of the test and evaluation fee. The test and evaluation fee is subject to change without prior notice.
5. If within the coverage of this limited warranty, BSE shall repair or replace the product at BSE's sole discretion and return the product via standard ground transportation of BSE's choosing within the continental US. The consumer shall be responsible for all transportation costs and insurance to return the product outside the continental US, and for all transportation costs and insurance related to expedited return of the product. BSE's liability for any defective product or any part thereof shall be limited to the repair or replacement of the product. BSE shall not be liable for any loss or damage to person or property, or any other damages, whether incidental, consequential or otherwise, caused by any defect in the product or any part thereof.
6. Any implied warranty for merchantability or fitness for a particular purpose is limited in duration to the length of this warranty.
7. To obtain warranty repairs, contact BSE at 760-597-1642 or techsupport@blueskyenergyinc.com to obtain a Returned Goods Authorization (RGA) number. Mark the outside of the package with the RGA number and return the product, postage prepaid and insured to the address below. The consumer is responsible for all transportation costs and insurance related to returning the product to BSE, and for any shipping damage which may void the warranty or increase the cost of repairs.