

Prüfbericht-Nr.: <i>Test report no.:</i>	CN24GUD4 001	Auftrags-Nr.: <i>Order no.:</i>	168499622	Seite 1 von 32 <i>Page 1 of 32</i>
Kunden-Referenz-Nr.: <i>Client reference no.:</i>	2606619	Auftragsdatum: <i>Order date:</i>	2024-07-16	
Auftraggeber: <i>Client:</i>	Rubix Battery LLC 2310 Township Road 444 Sugarcreek, OH 44681 USA			
Prüfgegenstand: <i>Test item:</i>	Lithium ion battery			
Bezeichnung / Typ-Nr.: <i>Identification / Type no.:</i>	RGS51100 51.2V 100AH			
Auftrags-Inhalt: <i>Order content:</i>	Test Report			
Prüfgrundlage: <i>Test specification:</i>	UL 9540A: 2019 (Fourth Edition)			
Wareneingangsdatum: <i>Date of sample receipt:</i>	2024-04-16			
Prüfmuster-Nr.: <i>Test sample no.:</i>	A003672973-001			
Prüfzeitraum: <i>Testing period:</i>	2024-04-28 - 2024-04-29			
Ort der Prüfung: <i>Place of testing:</i>	See to clause 1.1 of main report			
Prüflaboratorium: <i>Testing laboratory:</i>	See to clause 1.1 of main report			
Prüfergebnis*: <i>Test result*:</i>	See main report			
erstellt von: <i>created by:</i>	 Jason Zhu Project Engineer		genehmigt von: <i>authorized by:</i>	 Xun Yu Reviewer
Datum: <i>Date:</i>	2024-08-21		Ausstellungsdatum: <i>Issue date:</i>	2024-08-21
Stellung / Position:	Project Engineer		Stellung / Position:	Reviewer
Sonstiges / <i>Other:</i>	This report does not evidence compliance of the provided sample with the relevant standards but only with the referred tests. This test report documents the findings of examination conducted on the delivered product mentioned above only. This report does not entitle the applicant to carry any safety mark on this or similar products. Further for sales or other application purposes of the tested product, any reference to TÜV Rheinland or a test through TÜV Rheinland is only permissible with prior written consent of TÜV Rheinland.			
Zustand des Prüfgegenstandes bei Anlieferung: <i>Condition of the test item at delivery:</i>	Prüfmuster vollständig und unbeschädigt <i>Test item complete and undamaged</i>			
* Legende:	P(ass) = entspricht o.g. Prüfgrundlage(n)	F(ail) = entspricht nicht o.g. Prüfgrundlage(n)	N/A = nicht anwendbar	N/T = nicht getestet
* Legend:	P(ass) = passed a.m. test specification(s)	F(ail) = failed a.m. test specification(s)	N/A = not applicable	N/T = not tested
<p>Dieser Prüfbericht bezieht sich nur auf das o.g. Prüfmuster und darf ohne Genehmigung der Prüfstelle nicht auszugsweise vervielfältigt werden. Dieser Bericht berechtigt nicht zur Verwendung eines Prüfzeichens. <i>This test report only relates to the a. m. test sample. Without permission of the test center this test report is not permitted to be duplicated in extracts. This test report does not entitle to carry any test mark.</i></p>				

Prüfbericht-Nr.: CN24GUD4 001
Test report no.:

Seite 2 von 32
Page 2 of 32

Anmerkungen
Remarks

1	<p>Alle eingesetzten Prüfmittel waren zum angegebenen Prüfzeitraum gemäß eines festgelegten Kalibrierungsprogramms unseres Prüfhauses kalibriert. Sie entsprechen den in den Prüfprogrammen hinterlegten Anforderungen. Die Rückverfolgbarkeit der eingesetzten Prüfmittel ist durch die Einhaltung der Regelungen unseres Managementsystems gegeben. Detaillierte Informationen bezüglich Prüfbedingungen, Prüfequipment und Messunsicherheiten sind im Prüflabor vorhanden und können auf Wunsch bereitgestellt werden.</p> <p><i>The equipment used during the specified testing period was calibrated according to our test laboratory calibration program. The equipment fulfils the requirements included in the relevant standards. The traceability of the test equipment used is ensured by compliance with the regulations of our management system. Detailed information regarding test conditions, equipment and measurement uncertainty is available in the test laboratory and could be provided on request.</i></p>
2	<p>Wie vertraglich vereinbart, wurde dieses Dokument nur digital unterzeichnet. Der TÜV Rheinland hat nicht überprüft, welche rechtlichen oder sonstigen diesbezüglichen Anforderungen für dieses Dokument gelten. Diese Überprüfung liegt in der Verantwortung des Benutzers dieses Dokuments. Auf Verlangen des Kunden kann der TÜV Rheinland die Gültigkeit der digitalen Signatur durch ein gesondertes Dokument bestätigen. Diese Anfrage ist an unseren Vertrieb zu richten. Eine Umweltgebühr für einen solchen zusätzlichen Service wird erhoben. Informationen zur Verifizierung der Authentizität unserer Dokumente erhalten Sie über folgenden Link: Einführung in digitale Signaturen</p> <p><i>As contractually agreed, this document has been signed digitally only. TÜV Rheinland has not verified and unable to verify which legal or other pertaining requirements are applicable for this document. Such verification is within the responsibility of the user of this document. Upon request by its client, TÜV Rheinland can confirm the validity of the digital signature by a separate document. Such request shall be addressed to our Sales department. An environmental fee for such additional service will be charged. For information on verifying the authenticity of our documents, please visit the following link: Introduction to Digital Signature</i></p>
3	<p>Prüfklausel mit der Note * wurden an qualifizierte Unterauftragnehmer vergeben und sind unter der jeweiligen Prüfklausel des Berichts beschrieben. Abweichungen von Prüfspezifikation(en) oder Kundenanforderungen sind in der jeweiligen Prüfklausel im Bericht aufgeführt.</p> <p><i>Test clauses with remark of * are subcontracted to qualified subcontractors and described under the respective test clause in the report. Deviations of testing specification(s) or customer requirements are listed in specific test clause in the report.</i></p>
4	<p>Die Entscheidungsregel für Konformitätserklärungen basierend auf numerischen Messergebnissen in diesem Prüfbericht basiert auf der "Null-Grenzwert-Regel" und der "Einfachen Akzeptanz" gemäß ILAC G8:2019 und IEC Guide 115:2021, es sei denn, in der auf Seite 1 dieses Berichts genannten angewandten Norm ist etwas anderes festgelegt oder vom Kunden gewünscht. Dies bedeutet, dass die Messunsicherheit nicht berücksichtigt wird und daher auch nicht im Prüfbericht angegeben wird. Zu weiteren Informationen bezueglich des Risikos durch diese Entscheidungsregel siehe ILAC G8:2019.</p> <p><i>The decision rule for statements of conformity, based on numerical measurement results, in this test report is based on the "Zero Guard Band Rule" and "Simple Acceptance" in accordance with ILAC G8:2019 and IEC Guide 115:2021, unless otherwise specified in the applied standard mentioned on Page 1 of this report or requested by the customer. This means that measurement uncertainty is not taken in account and hence also not declared in the test report. For additional information to the resulting risk based of this decision rule please refer to ILAC G8:2019.</i></p>

INTRODUCTION

Model fire codes and energy storage system standards require energy storage systems to comply with UL 9540, which in turn requires battery cells and modules to comply with UL 1973. Compliance with these standards reduces the risk of batteries and battery energy storage systems (BESS) creating fire, shock or personal injury hazards. However, they don't evaluate the ability of the BESS installed as intended and with fire suppression mechanisms in place if necessary, from contributing to a fire or explosion in the end use installations.

To address these fire and explosion hazards associated with the installation of a BESS, the fire and other codes require energy storage systems to meet certain location, separation, fire suppression and other criteria. Those codes also provide a means to provide an equivalent level of safety based on large scale fire testing of anticipated BESS installations.

UL 9540A is intended to provide a test method that can be used as a basis for validating the safety of a BESS installation in lieu of meeting the specific criteria provided in those codes. The data generated can be used to determine the fire and explosion protection required for installation of a BESS.

The test method is initiated through the establishment of a thermal runaway condition that leads to combustion within the BESS. The test method outlined in UL 9540A consists of several steps – cell level testing, module level testing, unit level testing and installation level testing. The cell and module level testing steps are information gathering steps to inform the unit and installation level testing.

The following outlines the information that may gathered as part of the testing:

- a) Cell level – An individual cell fails in a manner that leads to thermal runaway and fire through a suitable method such as external heating. Data such as off-gassing contents, temperatures at venting and temperatures at thermal runaway are recorded.
- b) Module level – One or more cells within a BESS module fail in the manner determined during the cell level testing. Data such as fire propagation in the module, temperatures on the failed cells and surrounding cells, off-gassing contents and heat release data are gathered.
- c) Unit level – A complete BESS is installed surrounded by target (e.g. dummy) BESS and walls separated at a distance as intended in its installation. The module level test is repeated on a module located in the BESS in the most unfavorable location. Data such as temperature within the BESS, on surrounding walls and target BESS; incident heat flux on walls and target BESS; observation of fire propagation from BESS to target units and walls as well as observance of explosions or evidence of re-ignition within the BESS; and heat release and off-gassing contents are gathered.
- d) Installation level – This test is a repeat of the unit level test with the test conducted within a test room and with the intended fire suppression system installed as well as any overhead cables (that can lead to fire propagation) installed. This test is intended to validate the fire suppression system for the BESS installation. Data such as temperature within the BESS, on surrounding walls and target BESS; incident heat flux on walls and target BESS; fire propagation from the BESS to target units, walls or overhead cables and any observable explosion incidents or re-ignition within the BESS; and off-gassing contents (if needed) and heat release are gathered.

Contents

1	GENERAL INFORMATION	4
1.1	TEST SPECIFICATION	4
1.2	GENERAL REMARKS	4
1.3	REVISION INFORMATION	4
1.4	SUMMARY OF THE TEST	5
1.5	DEFINITIONS	6
2	GENERAL PRODUCT INFORMATION	7
2.1	CELL	7
2.2.1	<i>Product information and parameters</i>	<i>7</i>
2.2.2	<i>Cell level test information</i>	<i>8</i>
2.2	MODULE	8
2.2.1	<i>Product information and parameters</i>	<i>8</i>
2.2.2	<i>Diagram with overall dimension</i>	<i>9</i>
3	MODULE LEVEL TEST (SECTION 8 OF UL 9540A).....	9
3.1	GENERAL	9
3.2	SAMPLE PREPARATION	10
3.3	MODULE LEVEL THERMAL RUNAWAY TEST	11
3.3.1	<i>Thermal runaway test method description</i>	<i>11</i>
3.3.2	<i>Observations and records</i>	<i>13</i>
3.3.3	<i>Temperature measurements</i>	<i>14</i>
3.4	CHEMICAL HEAT RELEASE RATE MEASUREMENT	16
3.4.1	<i>Test method</i>	<i>16</i>
3.4.2	<i>Test result</i>	<i>18</i>
3.5	SMOKE RELEASE RATE MEASUREMENT	19
3.5.1	<i>Test method</i>	<i>19</i>
3.5.2	<i>Test result</i>	<i>20</i>
3.6	GAS GENERATION MEASUREMENT	21
3.6.1	<i>Test method</i>	<i>21</i>
3.6.2	<i>Total gas release</i>	<i>21</i>
3.6.3	<i>Gas components</i>	<i>22</i>
3.7	PHOTOS	29

Prüfbericht - Nr.: CN24GUD4 001
Test Report No.:

Seite 5 von 32
Page 5 of 32

1 General information

1.1 Test specification

Standard: ANSI/CAN/UL 9540A: 2019 (Fourth Edition)

Test Method for Evaluating Thermal Runaway Fire Propagation in Battery Energy Storage Systems

This report presents the result of module level tests of UL 9540A: 2019.

All tests were conducted at TUV Rheinland (Shenzhen) Co., Ltd. and TUV Rheinland's partner labs that were under supervision of TÜV Rheinland's engineer.

Testing period: 2024.04.28 to 2024.04.29

Refer to Clause 3 for test and measurement instruments.

1.2 General remarks

This report is descriptive and provide the test data only.

The test results presented in this report relate only to the object tested.

This report shall not be reproduced, except in full, without the written approval of the testing laboratory.

Throughout this report a comma / point is used as the decimal separator.

1.3 Revision information

New report, not applicable.

1.4 Summary of the test

Video records of the test from 2 directions were provided in .mp4 format.

One external heater was placed in the module to initiate the thermal runaway inside the module. The initiating cells were heated at a rate of 4°C to 7°C per minute until the cell thermal runaway.

White smoke was observed during the test. No flying debris or explosive discharge of gases during the test. No sparks, electrical arcs, or other electrical events during the test. No external flaming observed.

The battery pack weight measured was 52.6kg (before test) and 49.6kg (after test).

Measured peak chemical heat release rate HRR was 9.24kW.

Measured total heat release through the test THR was 7.019MJ.

Measured peak smoke release rate SRR was 2.8555m²/s.

Total smoke release TSR was 2666.84m²

Total hydrocarbon gas was 1258.07L.

Detail information see relevant clause of this report.

1.5 Definitions

CELL – The basic functional electrochemical unit containing an assembly of electrodes, electrolyte, separators, container, and terminals. It is a source of electrical energy by direct conversion of chemical energy.

MODULE – A subassembly that is a component of a BESS that consists of a group of cells or electrochemical capacitors connected together either in a series and/or parallel configuration (sometimes referred to as a block) with or without protective devices and monitoring circuitry.

UNIT – A frame, rack or enclosure that consists of a functional BESS which includes components and subassemblies such as cells, modules, battery management systems, ventilation devices and other ancillary equipment.

BATTERY SYSTEM (BS) – Is a component of a BESS and consists of one or more modules typically in a rack configuration, controls such as the BMS and components that make up the system such as cooling systems, disconnects and protection devices.

BATTERY ENERGY STORAGE SYSTEM (BESS) – Stationary equipment that receives electrical energy and then utilizes batteries to store that energy to supply electrical energy at some future time. The BESS, at a minimum consists of one or more modules, a power conditioning system (PCS), battery management system (BMS) and balance of plant components.

a) **INITIATING BATTERY ENERGY STORAGE SYSTEM UNIT (INITIATING BESS)** – A BESS unit which has been equipped with resistance heaters in order to create the internal fire condition necessary for the installation level test.

b) **TARGET BATTERY ENERGY STORAGE SYSTEM UNIT (TARGET BESS)** – The enclosure and/or rack hardware that physically supports and/or contains the components that comprise a BESS. The target BESS unit does not contain energy storage components, but serves to enable instrumentation to measure the thermal exposure from the initiating BESS.

Note: Depending upon the configuration and design of the BESS (e.g. the BESS is composed of multiple separate parts within separate enclosures), the unit level test can be done at battery system level. In such case, the BESS is to be read as BS throughout this report.

NON-RESIDENTIAL USE – Intended for use in commercial, industrial or utility owned locations.

RESIDENTIAL USE – In accordance with this standard, intended for use in one or two family homes and town homes and individual dwelling units of multi-family dwellings.

THERMAL RUNAWAY- The incident when an electrochemical cell increases its temperature through self-heating in an uncontrollable fashion. The thermal runaway progresses when the cell's generation of heat is at a higher rate than the heat it can dissipate. This may lead to fire, explosion and gas evolution.

STATE OF CHARGE (SOC) – The available capacity in a BESS, pack, module or cell expressed as a percentage of rated capacity.

Prüfbericht - Nr.: CN24GUD4 001
Test Report No.:

Seite 8 von 32
Page 8 of 32

2 General Product Information

2.1 Cell

2.2.1 Product information and parameters

The product information and parameters are provided by the client as below.

Manufacturer:	JIANGXI GANFENG BATTERY TECHNOLOGY CO., LTD. Nanyuan Road, Hi-Tech Industrial Development Zone, Xinyu 338000 Jiangxi, P.R. China
Model number:	48173125-100Ah
Chemistry:	<input checked="" type="checkbox"/> LiFePO ₄ <input type="checkbox"/> NMC <input type="checkbox"/> NCA <input type="checkbox"/> LTO <input type="checkbox"/> Other:
Physical configuration:	<input checked="" type="checkbox"/> Prismatic <input type="checkbox"/> Cylindrical <input type="checkbox"/> Pouch Weight(kg): ≤2.30
Electrical rating :	Rated capacity (Ah): 100 Nominal voltage (V): 3.2
Standard charge method:	Charge current (A): 50 Standard Charge Voltage (V): 3.65 Cut off current (A): 5
Standard discharge method:	Discharge current (A): 50 End of discharge voltage (V): 2.5 (0°C<T≤60°C) 2.0 (-20°C≤T≤0°C)
Maximum continuous charge current (A):	100
Maximum continuous discharge current (A):	100
Compliance with UL 1973:	<input checked="" type="checkbox"/> Yes <u>UL MH63648</u> <input type="checkbox"/> No

Prüfbericht - Nr.: CN24GUD4 001
Test Report No.:

Seite 9 von 32
Page 9 of 32

2.2.2 Cell level test information

Cell level thermal runaway test information is copy from TUV Rheinland UL 9540A cell level test report No.: CN228KRW 001

Thermal Runaway Methodology:	External heater applied on one side of the cell with surface heating rate at about of 5°C per minute until thermal runaway triggered.
Average Cell Surface Temperature at Gas Venting:	202.0°C
Average Cell Surface Temperature Start Thermal Runaway:	272.4°C

2.2 Module

2.2.1 Product information and parameters

The product information and parameters are provided by the client as below.

Manufacturer:	Shandong Huison Electronics Technology Co.,Ltd Hanxin Industrial Park, Keda West Road, Yicheng District, Shandong Province, China	
Model number:	RGS51100 51.2V 100AH	
Physical configuration:	Metal base, the other sides are non-metallic material. A mica plate is installed under the top enclosure.	
	Weight:	≤50kg
	Cells in series/parallel:	1P16S
Cooling method:	Air cooling	
Separation between cells:	Thermal insulation sheet: Aerogel Heat insulation pad and Polyurethane foam, see Figure 4 for install location details.	
Electrical rating:	Rated capacity:	100 Ah
	Nominal voltage:	51.2Vdc
Standard charge method:	Charge Voltage:	57.6V
	End of charge:	The highest cell voltage reaches 3.65 V
Standard discharge method:	Discharge Voltage:	40V
	End of discharge:	The lowest cell voltage reaches 2.5V
Compliance with UL 1973:	<input type="checkbox"/> Yes	<input checked="" type="checkbox"/> No

2.2.2 Diagram with overall dimension

Figure 1 Diagram with overall dimension

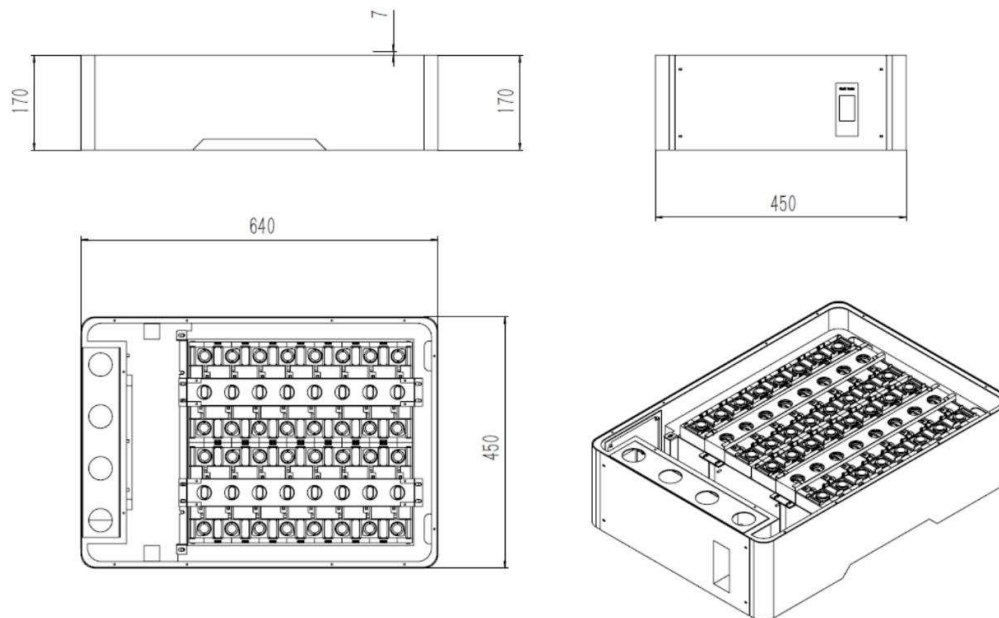

Unit: mm

3 Module level test (section 8 of UL 9540A)

3.1 General

This testing is conducted on battery modules, which are in turn installed in an enclosure or in an open rack system to form a BESS unit.

This test uses applied stresses determined during the cell level test to force a selected number of battery cells within the module into thermal runaway. If there is fire that results from the cell being driven into thermal runaway, the fire is allowed to progress within the module.

The test measures the chemical heat release rate, smoke release rate, maximum temperature, and vent gas composition; and documents the module enclosure integrity after the test, any explosions or hazardous ejection of parts outside of the module enclosure, and the extent and duration of any flame propagation outside of the module.

The module level testing establishes a base line fire test performance that can be evaluated against the fire performance of other battery modules the BESS manufacturer may choose to use within the system. Testing can be discontinued after the module level testing if the effects of thermal runaway (fire and explosion) are contained by the module design and the cell vent gas (as determined by the cell level testing) is non-flammable.

3.2 Sample preparation

Module sample was conditioned, prior to testing, through charge and discharge cycles of 2 cycles to verify that the module was functional.

Each cycle was defined as a charge to 100% SOC and allowed to rest several minutes and then discharged to an end of discharge voltage (EODV) determined by the manufacturer. Refer to 2.2.1 for charge and discharge profile.

The module sample was put in a climate chamber during charge and discharge. The ambient is kept at $25^{\circ}\text{C} \pm 2^{\circ}\text{C}$ and $50\% \pm 5\%$ R.H.

Figure 2 Sample cycling curve

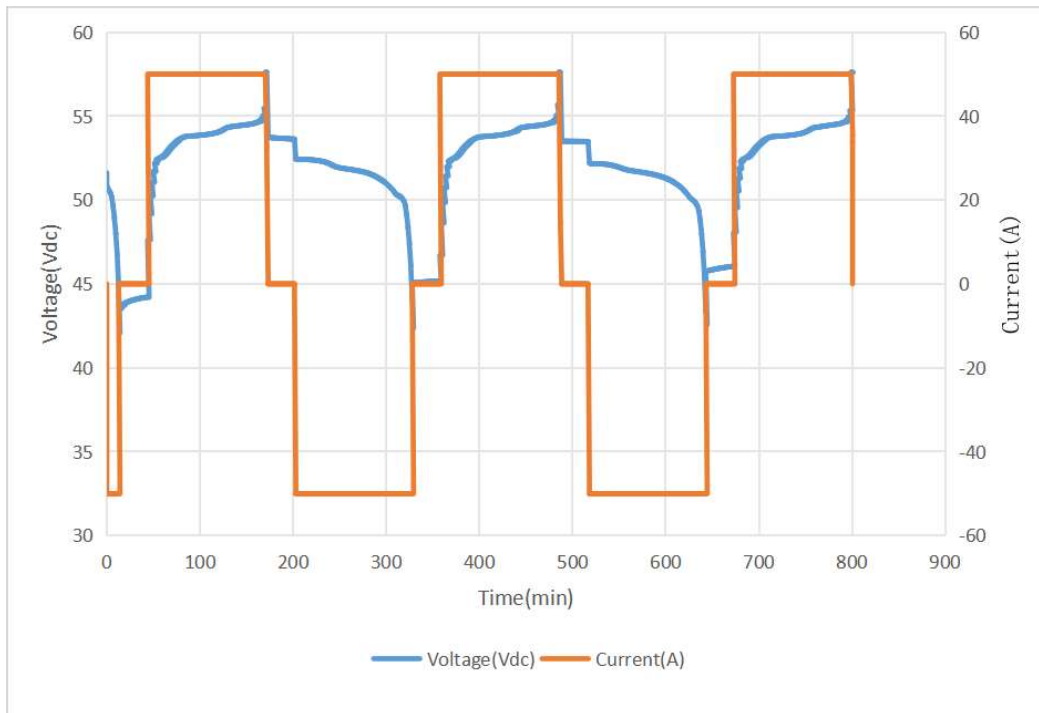

3.3 Module level thermal runaway test

3.3.1 Thermal runaway test method description

The module to be tested was charged to 100% SOC and allow stabilizing for a minimum of 1 h and a maximum of 8 h before the start of the test.

The module consisted of 16 cells 1P16S. All cells in the pack were numbered from Cell 1 to Cell 16 as below.

External heating method was used to initiate thermal runaway in the module. One metal heater was fitted on cell (rated 110V ac/195 W, size 150*100).

Total 11 thermocouples (type K, 24AWG) were attached at the center of the wider side surface of cell and below the hater film in the module. See Figure 3 and Figure 4 for the detail locations.

Voltage of the module was monitored during test.

Figure 3 Internal view of module

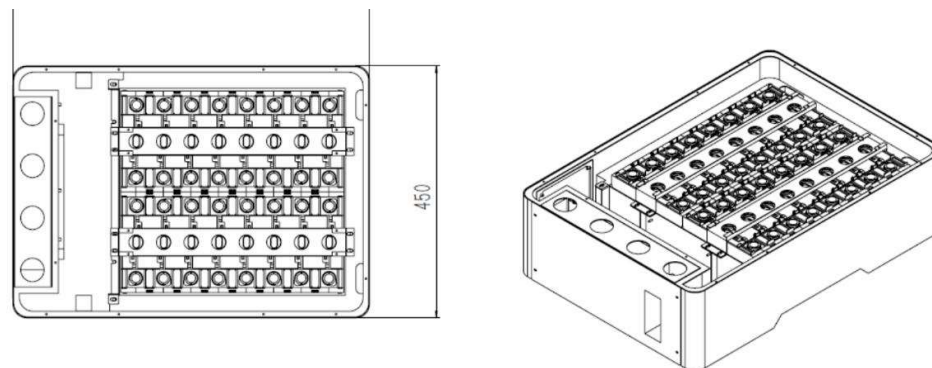
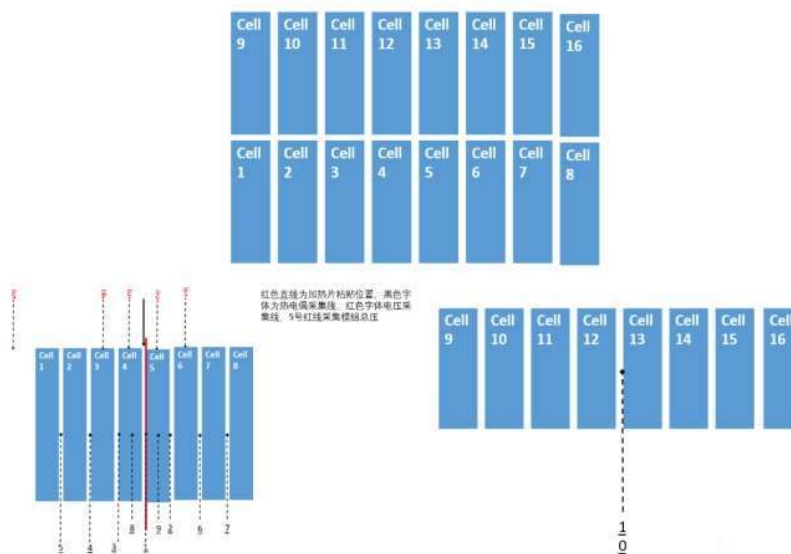

Figure 4 Cell number, location of heater, thermal insulation sheet (Aerogel Heat insulation pad and Polyurethane foam) and thermocouple



Prüfbericht - Nr.: CN24GUD4 001
Test Report No.:

Seite 13 von 32
Page 13 of 32

A PID controller was used to control the voltage supply to the heater and maintain a 4°C/min to 7°C/min heating rate. Additional one thermocouple on the center of initiating cell surface below heater was used to feedback the cell surface temperature to the controller.

The initiating cells were heated at a rate of 4°C to 7°C per minute until the cell thermal runaway.

Once the measured temperature exceed the set heating rate, the heaters were immediately de-energized.

3.3.2 Observations and records

Ambient conditions at the initiation of the test .:	24.8°C, 65% R.H.
Sample number :	A003672973-001
Open circuit voltage before test (V) :	55.91V
Weight before test (kg) :	52.6kg
Time initiating the test :	2024.4.28 14:09:10
Observations during test :	<p>The first thermal runaway cell (Cell 4) and smoke release at 15:16</p> <p>The second thermal runaway cell (Cell 5) at 15:18.</p> <p>The third thermal runaway cell (Cell 6) at 15:20.</p> <p>The fourth thermal runaway cell (Cell 3) at 15:26.</p> <p>The five thermal runaway cell (Cell 7) at 15:28.</p> <p>The six thermal runaway cell (Cell 2) at 15:34.</p> <p>The seven thermal runaway cell (Cell 8) at 15:48.</p> <p>The eight thermal runaway cell (Cell 1) at 16:02.</p> <p>No flying debris or explosive discharge of gases during test.</p> <p>No sparks, electrical arcs, or other electrical events during test.</p> <p>No external flaming observe.</p>
Open circuit voltage after test (V) :	26.24V
Weight after test (kg) :	49.6kg
Weight loss (kg) :	3kg

3.3.3 Temperature measurements

Figure 5 The cells temperature and module voltage VS time curve

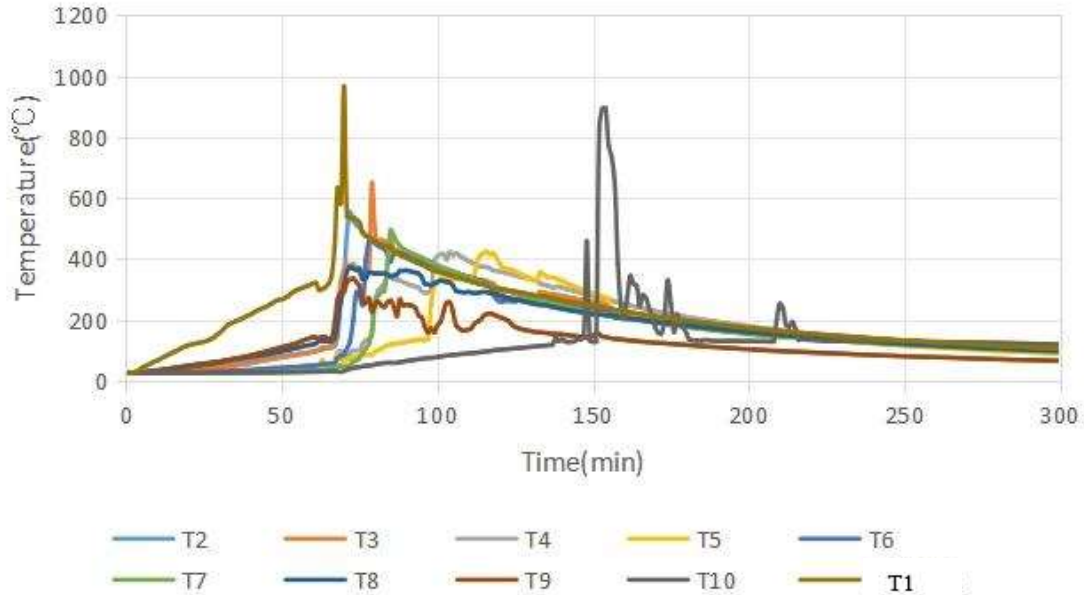

Thermocouple no.	Location	Maximum temp. °C
T1	Heater	553.1
T2	Surface of cell 5	648.9
T3	Surface of cell 4	422.5
T4	Surface of cell 3	422.4
T5	Surface of cell 2	463.6
T6	Surface of cell 7	493.9
T7	Surface of cell 8	372.6
T8	Surface of cell 4	334.8
T9	Surface of cell 5	894.8
T10	Surface of cell 13	553.1

Voltage no.	Name	Voltage(V)
DV1	Voltage of Module	54.7V to 0 V
V_1	Voltage of Cell6	3.409V to 0.231 V
V_2	Voltage of Cell5	3.418V to 0.206 V
V_3	Voltage of Cell4	3.408V to 0.231 V
V_4	Voltage of Cell3	3.416V to 0.208 V

Figure 6 The enclosure temperature VS time curve

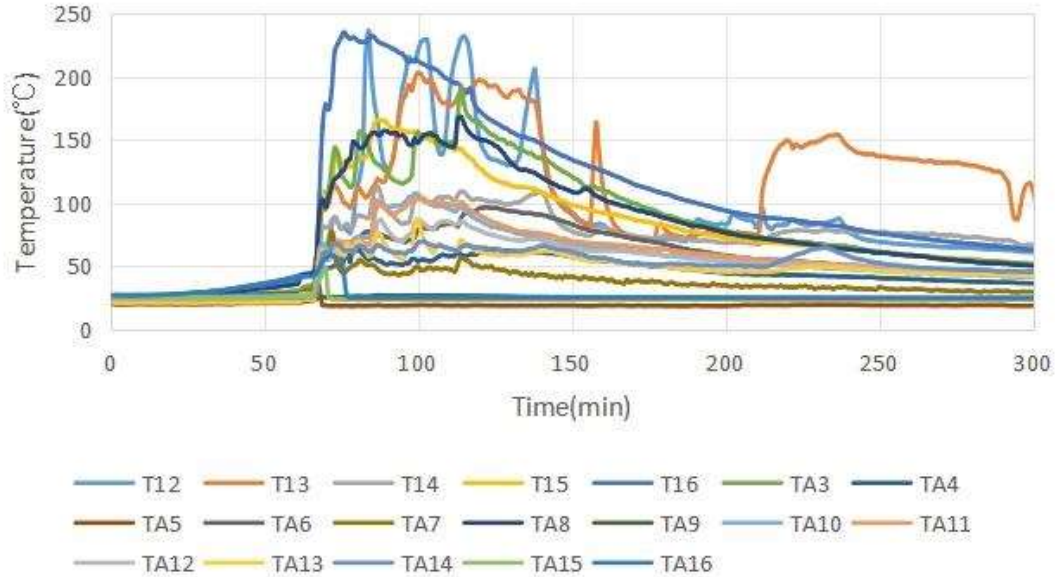

Thermocouple no.	Location	Maximum temp. °C
T11	Top surface of the Enclosure	236.5
T12	Top surface of the Enclosure	203.2
T13	Top surface of the Enclosure	112.9
T14	Top surface of the Enclosure	165.8
T15	Top surface of the Enclosure	235.4
T16	Top surface of the Enclosure	192.3
T17	Right surface of the Enclosure	70.7
T18	Right surface of the Enclosure	39.1
T19	Right surface of the Enclosure	96.7
T21	Back surface of the Enclosure	77.4
T22	Back surface of the Enclosure	168.3
T23	Back surface of the Enclosure	27
T24	Back surface of the Enclosure	105.8
T25	Left surface of the Enclosure	104.5
T26	Left surface of the Enclosure	87.0
T27	Front surface of the Enclosure	86.9

T28	Front surface of the Enclosure	69.6
T29	Front surface of the Enclosure	48.9
T30	Botton surface of the Enclosure	58.8

Figure 7 The cells and module voltage VS time curve

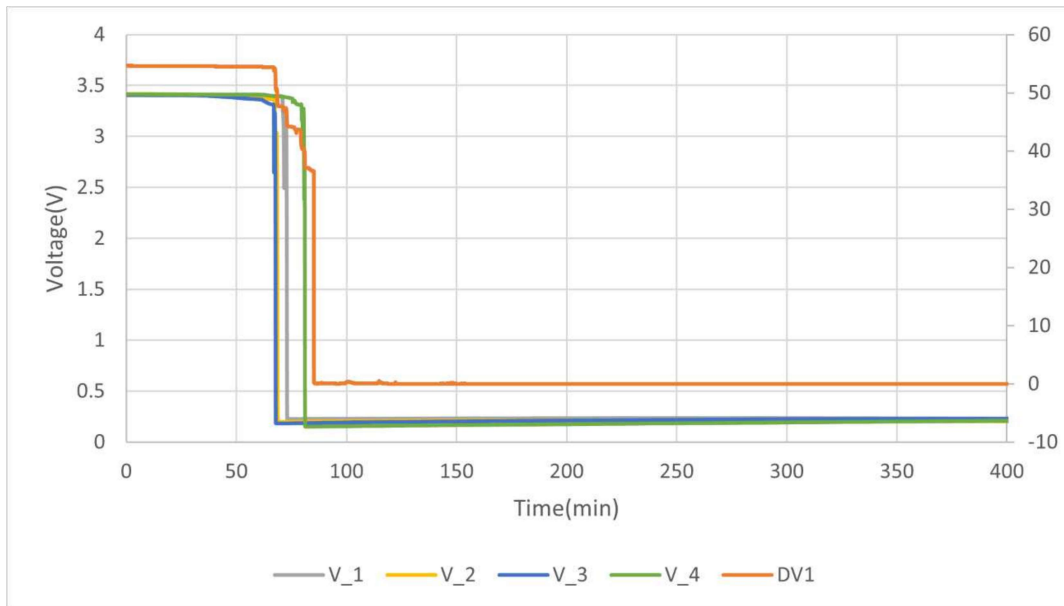

Name	V_1	V_2	V_3	V_4	DV1
Begin of the test	3.409V	3.418 V	3.408 V	3.416 V	54.7 V
End of the test	0.231V	0.206 V	0.231 V	0.208 V	0 V*

Remark:

* Due to the abnormal voltage sampling line in the test, the actual voltage can not be picked up, and the actual voltage of the module after the test is 26.24V

3.4 Chemical heat release rate measurement

3.4.1 Test method

The chemical heat release rates were measured by an oxygen consumption calorimeter measurement system consisting of a paramagnetic oxygen analyzer, non-dispersive infrared carbon dioxide and carbon monoxide analyzer, velocity probe, and a Type K thermocouple.

The instrumentations are located in the exhaust duct of the heat release rate calorimeter.

The chemical heat release rate was calculated at each of the flows as follows:

$$HRR_1 = \left[E \times \varphi - (E_{CO} - E) \times \frac{1 - \varphi}{2} \times \frac{X_{CO}}{X_{O_2}} \right] \times \frac{\dot{m}_e}{1 + \varphi \times (\alpha - 1)} \times \frac{M_{O_2}}{M_a} \times (1 - X_{H_2O}^o) \times X_{O_2}^o$$

In which:

HRR_t = total heat release rate, as a function of time (kW)

E = Net heat released for complete combustion per unit of oxygen consumed (adjusted for oxygen contained within cell chemistry, 13,100 kJ/kg)

E_{CO} = Net heat released for complete combustion per unit of oxygen consumed, for CO (adjusted for oxygen contained within cell chemistry, 17,600 kJ/kg)

φ = Oxygen depletion factor (non-dimensional), where:

$$\varphi = \frac{X_{O_2}^o \times [1 - X_{CO_2} - X_{CO}] - X_{O_2} \times [1 - X_{CO_2}^o]}{X_{O_2}^o \times [1 - X_{O_2} - X_{CO_2} - X_{CO}]}$$

X_{CO} = Measured mole fraction of CO in exhaust flow (non-dimensional)

X_{CO_2} = Measured mole fraction of CO₂ in exhaust flow (non-dimensional)

$X_{CO_2}^o$ = Measured mole fraction of CO₂ in incoming air (non-dimensional)

$X_{H_2O}^o$ = Measured mole fraction of H₂O in incoming air (non-dimensional)

X_{O_2} = Measured mole fraction of O₂ in exhaust flow (non-dimensional)

$X_{O_2}^o$ = Measured mole fraction of O₂ in incoming air (non-dimensional)

α = Combustion expansion factor (non-dimensional; normally a value of 1.105)

M_a = Molecular weight of incoming and exhaust air (29 kg/kmol)

M_{O_2} = Molecular weight of oxygen (32 kg/kmol)

\dot{m}_e = Mass flow rate in exhaust duct (kg/s), in which:

$$\dot{m}_e = C \times \sqrt{\frac{\Delta p}{T_e}}$$

or

$$\dot{m}_e = 26.54 \times \frac{A \times k_c}{f(Re)} \times \sqrt{\frac{\Delta p}{T_e}}$$

C = Orifice plate coefficient (in kg^{1/2}m^{1/2}K^{1/2})

Δp = Pressure drop across orifice plate or bidirectional probe (Pa)

T_e = Combustion gas temperature at orifice plate or bidirectional probe (K)

A = Cross sectional area of the duct (m²)

k_c = Velocity profile shape factor (non-dimensional)

$f(Re)$ = Reynolds number correction (non-dimensional)

3.4.2 Test result

Peak chemical heat release rate HRR: 9.24kW

Total heat release through the test THR: 7.019 MJ

Figure 8 HRR curve

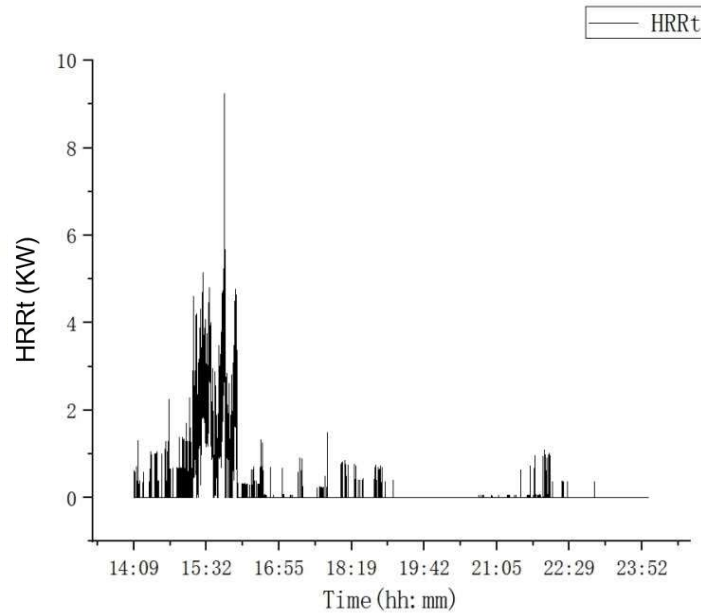
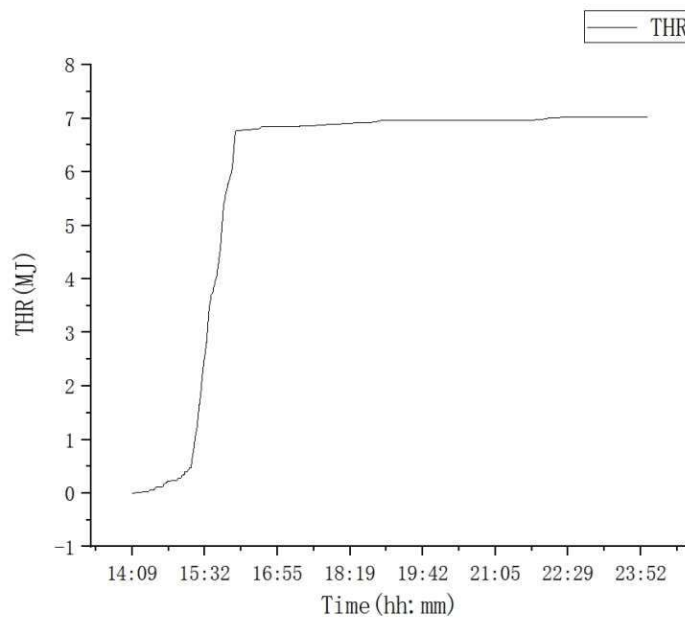

Figure 9 THR curve



3.5 Smoke release rate measurement

3.5.1 Test method

The light transmission in the calorimeter's exhaust duct was measured using a white light source and photo detector for the duration of the test.

The smoke release rate was calculated as follows:

$$SRR = 2.303 \left(\frac{V}{D} \right) \text{Log}_{10} \left(\frac{I_0}{I} \right)$$

Where:

SRR = Smoke release rate (m²/s)

V = Volumetric exhaust duct flow rate (m³/s)

D = duct diameter (m)

*I*₀ = Light transmission signal of clear (pre-test) beam (V)

I = Light transmission signal during test (V)

The whole smoke release rate measurement system were self-checked using calibrated light filter before test.

3.5.2 Test result

Peak smoke release rate SRR: 2.8555m²/s

Total smoke release TSR: 2666.84m²

Figure 10 SRR curve

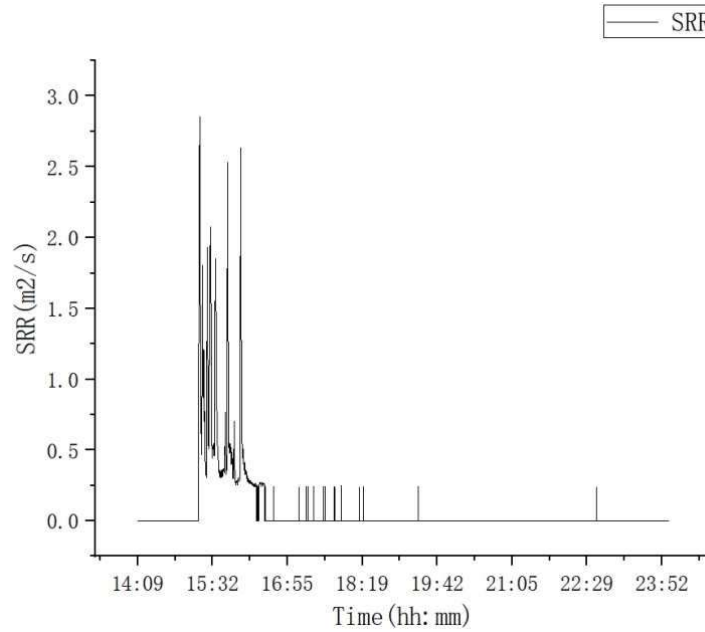
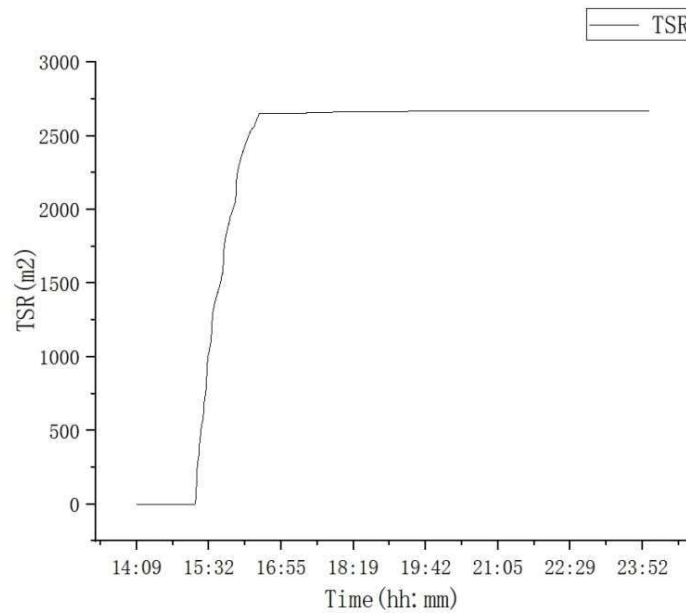

Figure 11 TSR curve



3.6 Gas generation measurement

3.6.1 Test method

The composition, velocity and temperature of the vent gases were measured within the calorimeter's exhaust duct.

Gas composition were measured using a Fourier-Transform Infrared Spectrometer with a resolution of 0.5 cm⁻¹ and a path length of 5.1 m within the calorimeter's exhaust duct.

The hydrocarbon content of the vent gas was measured using flame ionization detection.

Hydrogen gas was measured with a palladium-nickel thin-film solid state sensor.

Composition, velocity and temperature instrumentation were collocated with heat release rate calorimetry instrumentation

3.6.2 Total gas release

The flow rates of various gases were integrated over the test duration and the total cumulative volume of gas calculated for the total test duration were presented in below table.

Gas type	Gas components		Total volume of gas (L)
Hydrocarbon species	Methane	CH ₄	34.17
	Ethylene	C ₂ H ₄	45.26
	Ethane	C ₂ H ₆	9.55
	Propylene	C ₃ H ₆	49.86
	Propane	C ₃ H ₈	17.62
Others	Carbon Monoxide	CO	33.4
	Carbon Dioxide	CO ₂	68.9
	Hydrogen (Palladium nickel thin film solid state sensor)	H ₂	Below detectable limit*
Total Hydrocarbons (equivalent to CH ₄ , measured by FID)			1258.07

3.6.3 Gas components

Concentration of different gas components were present according to gas species classification in Figures 12 to 14. Average flow rate was 2.01 m³/s during test.

Figure 12 Hydrocarbon species:

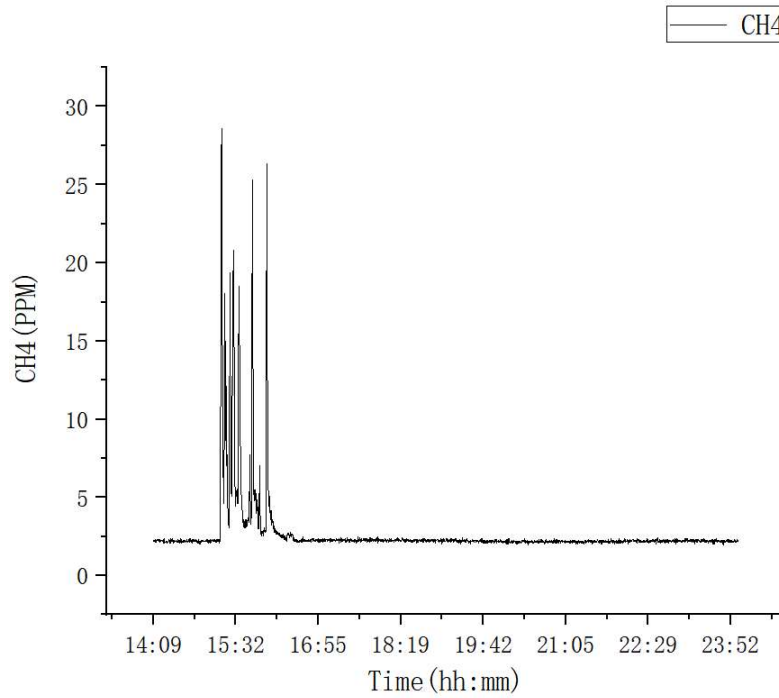

Prüfbericht - Nr.: CN24GUD4 001
Test Report No.:

Seite 24 von 32
Page 24 of 32

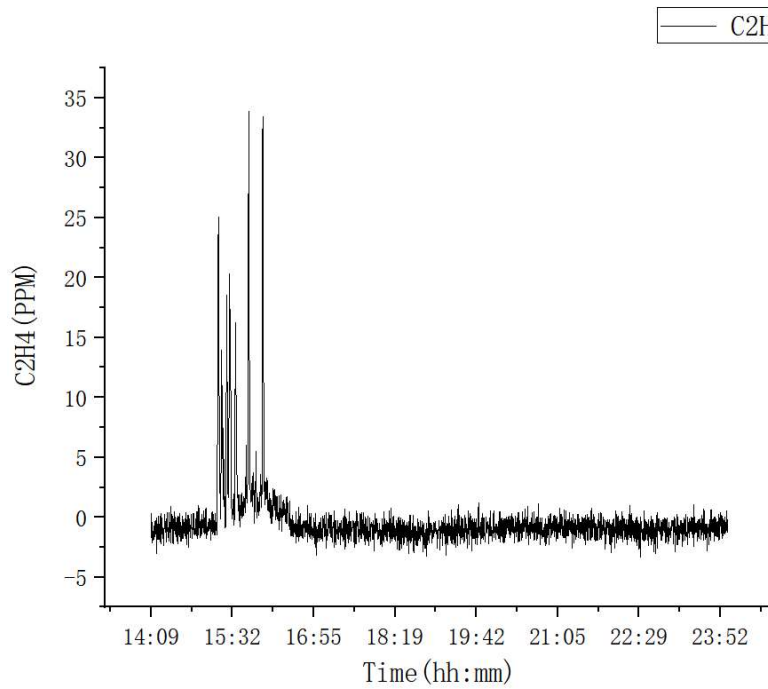
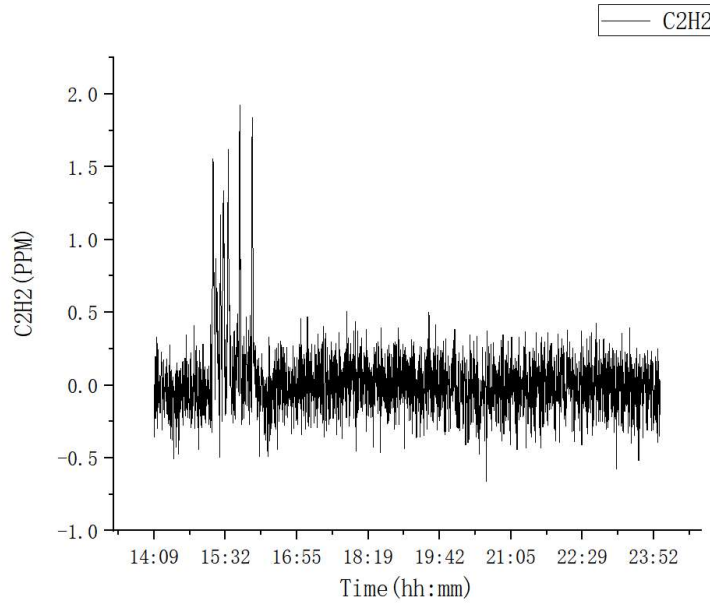

Prüfbericht - Nr.: CN24GUD4 001
Test Report No.:

Seite 25 von 32
Page 25 of 32

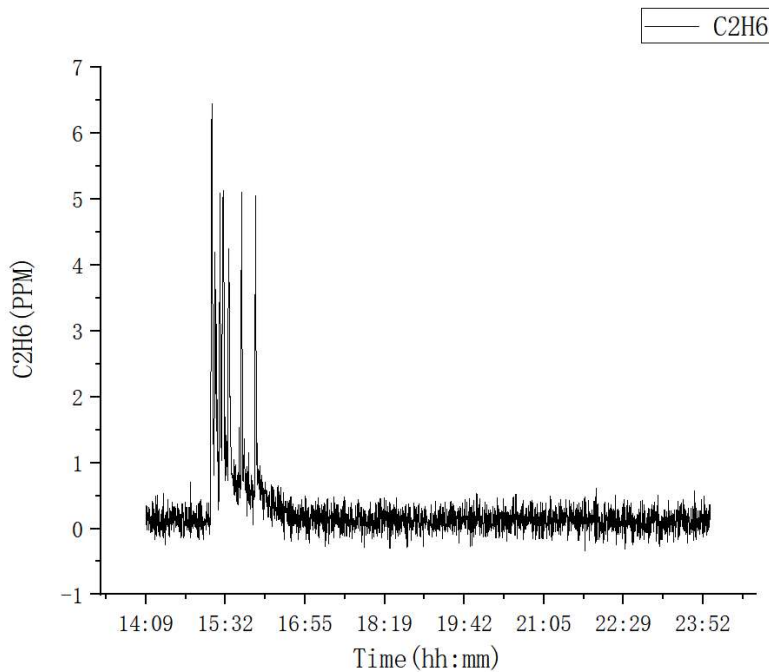
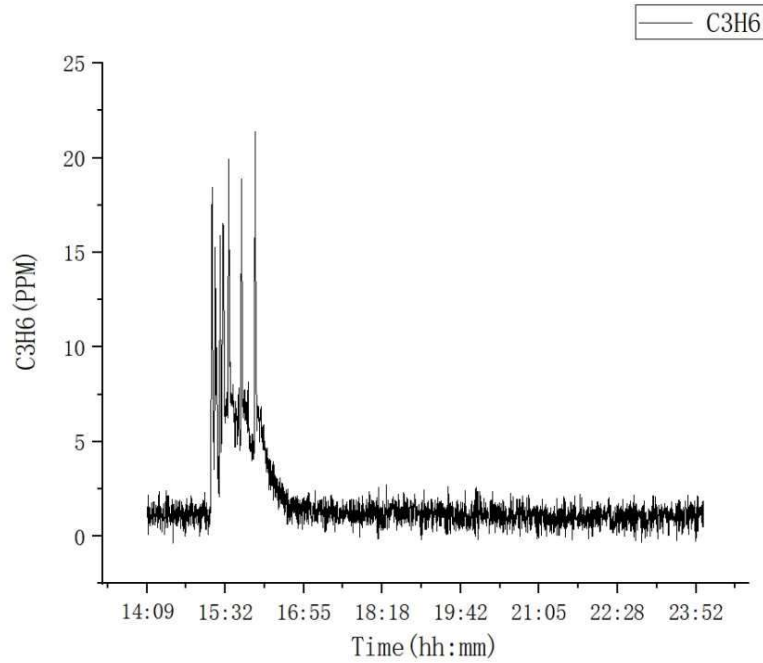

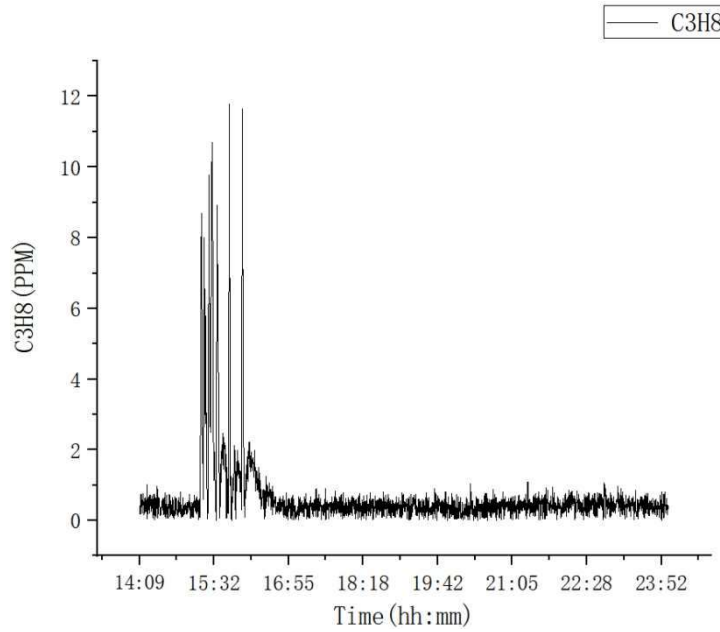
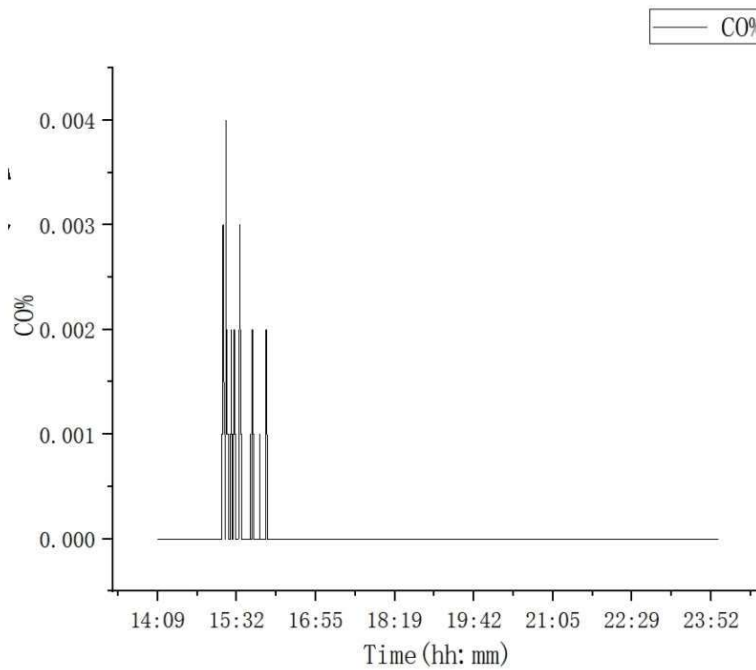

Figure 13 CO, CO₂ concentration:



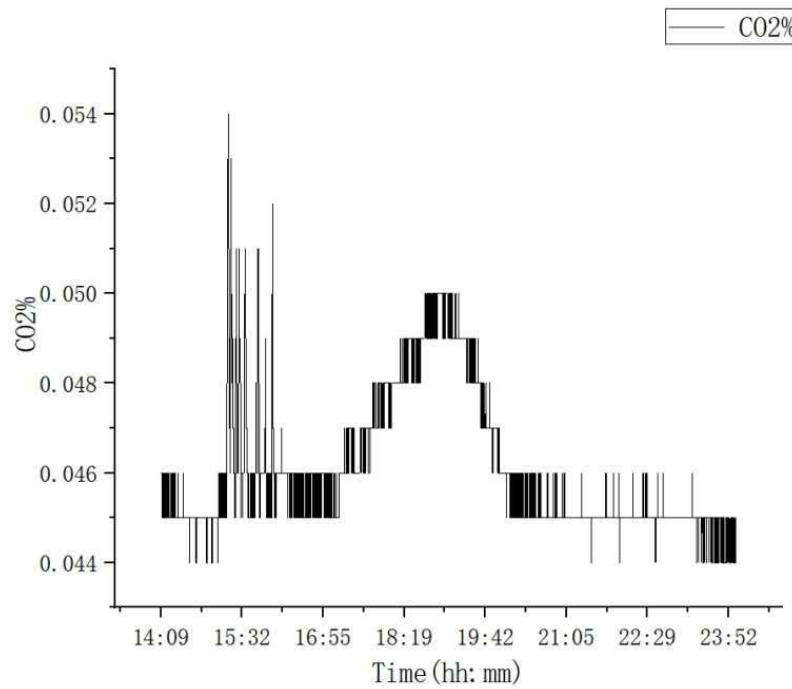
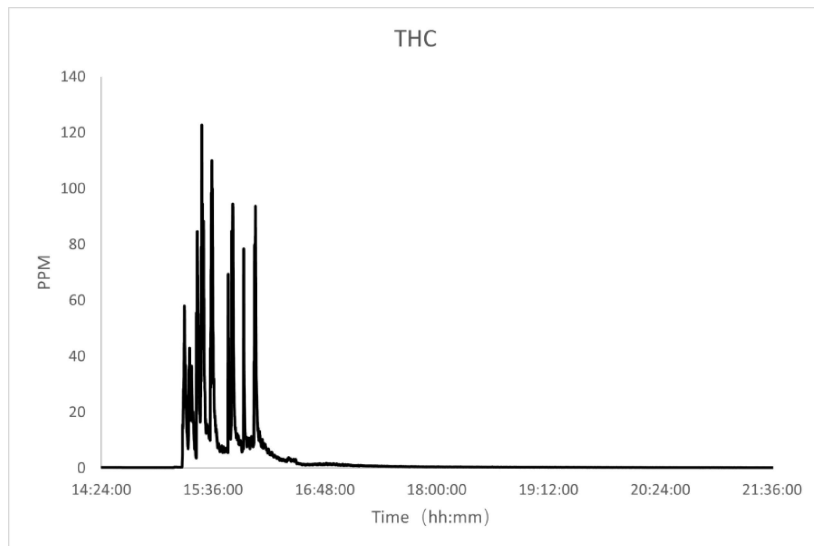
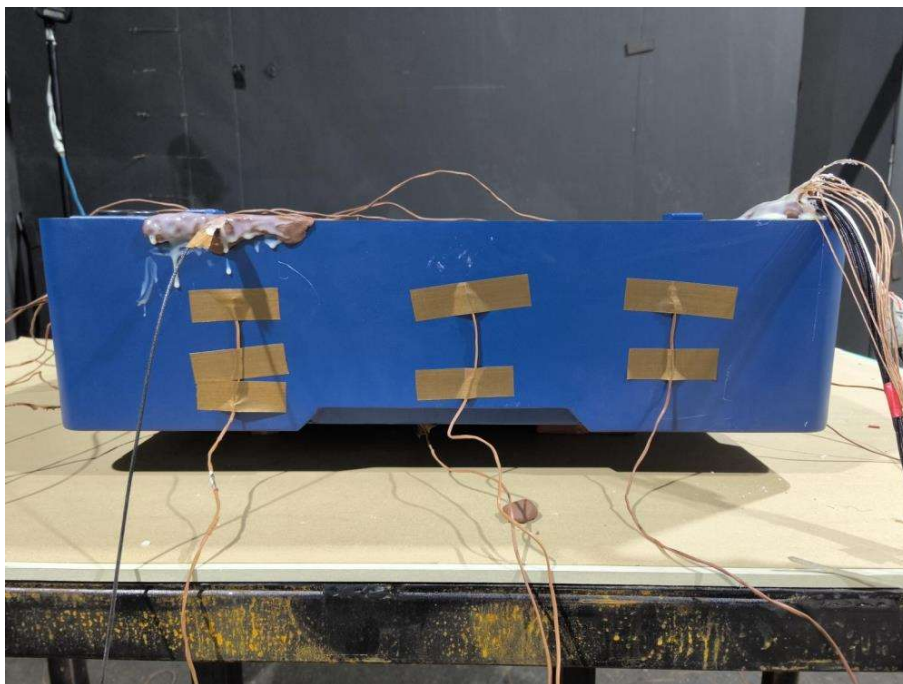
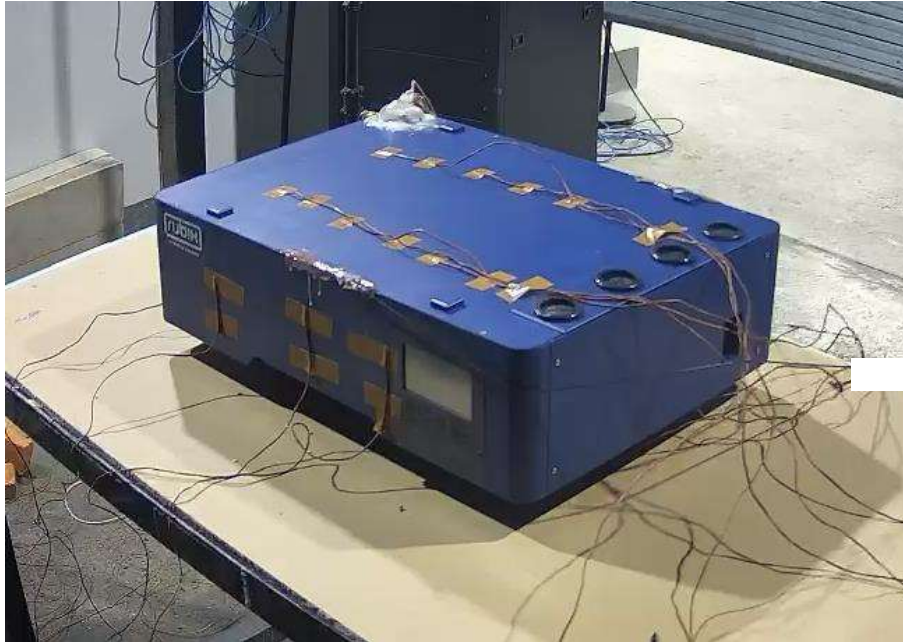

Figure 14 Total Hydrocarbons (equivalent to CH₄, measured by FID):



3.7 Photos

Module before test



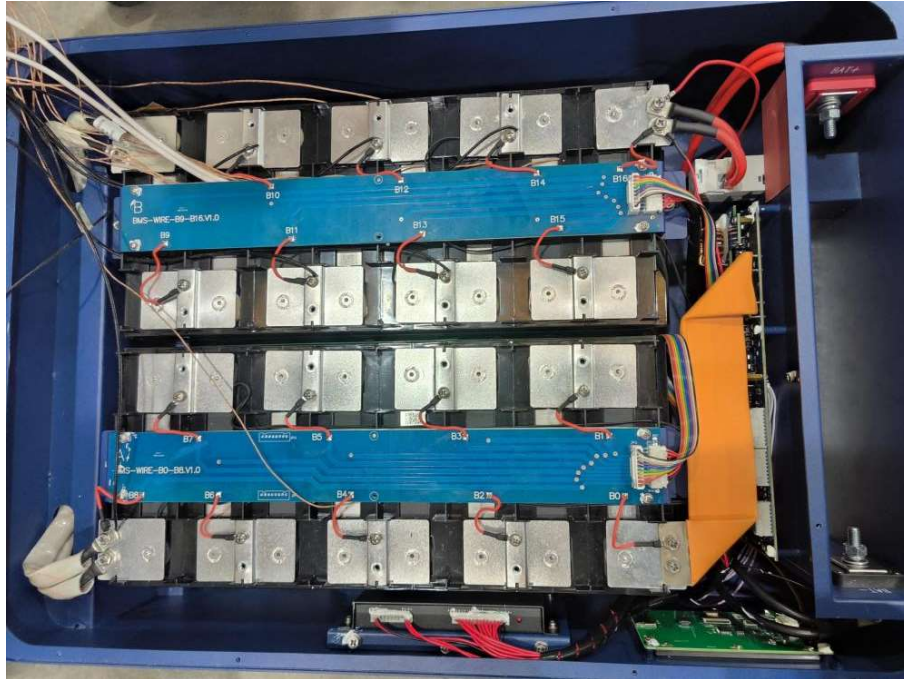

Smoke release during test



Sample after test

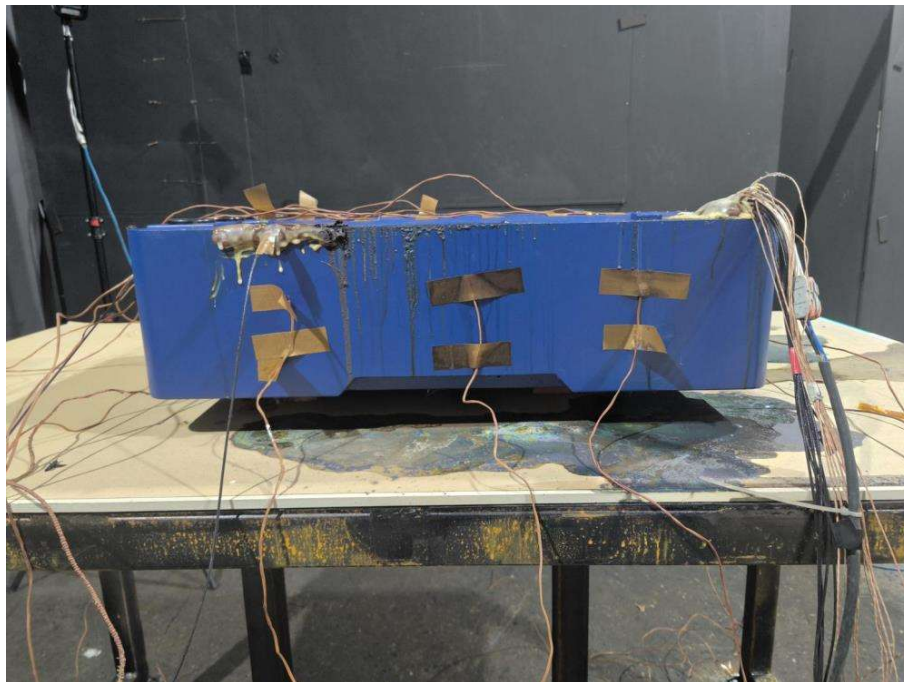
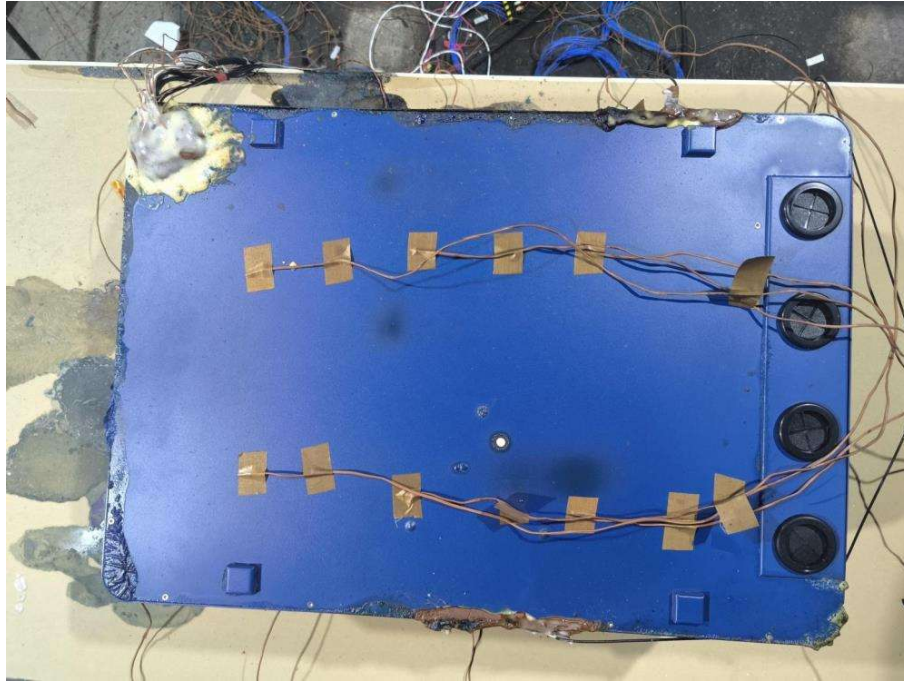

Prüfbericht - Nr.: CN24GUD4 001
Test Report No.:

Seite 31 von 32
Page 31 of 32

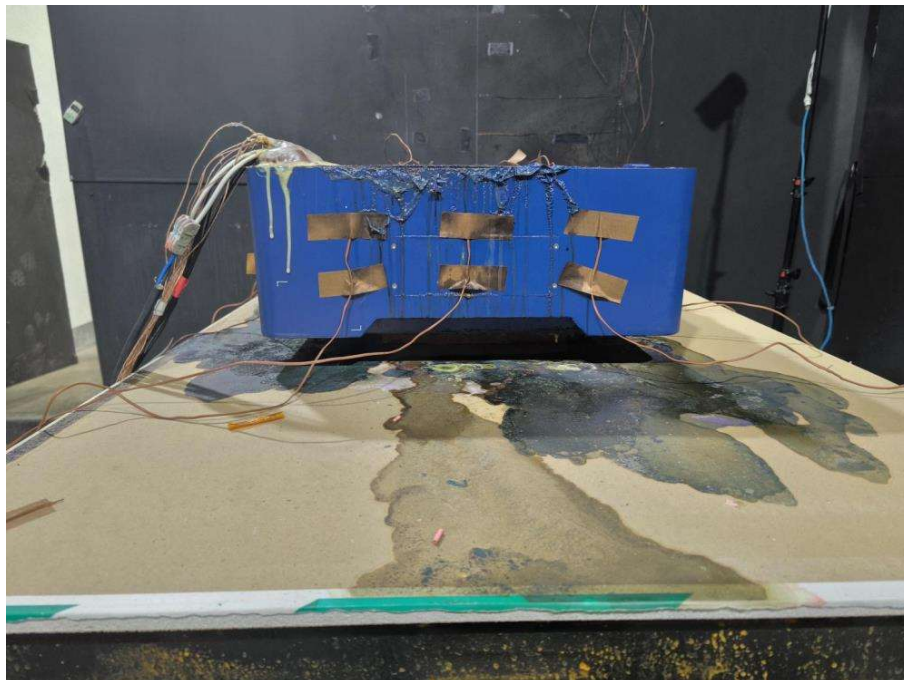

Prüfbericht - Nr.: CN24GUD4 001
Test Report No.:

Seite 32 von 32
Page 32 of 32

Damage of the internal components



End of Test Report