

Rafter or Deck Attach

- ▶ 4 screws in the corners for deck attach
- ▶ 1 lag screw in the center for rafter attach
- ▶ Compatible with all roof types

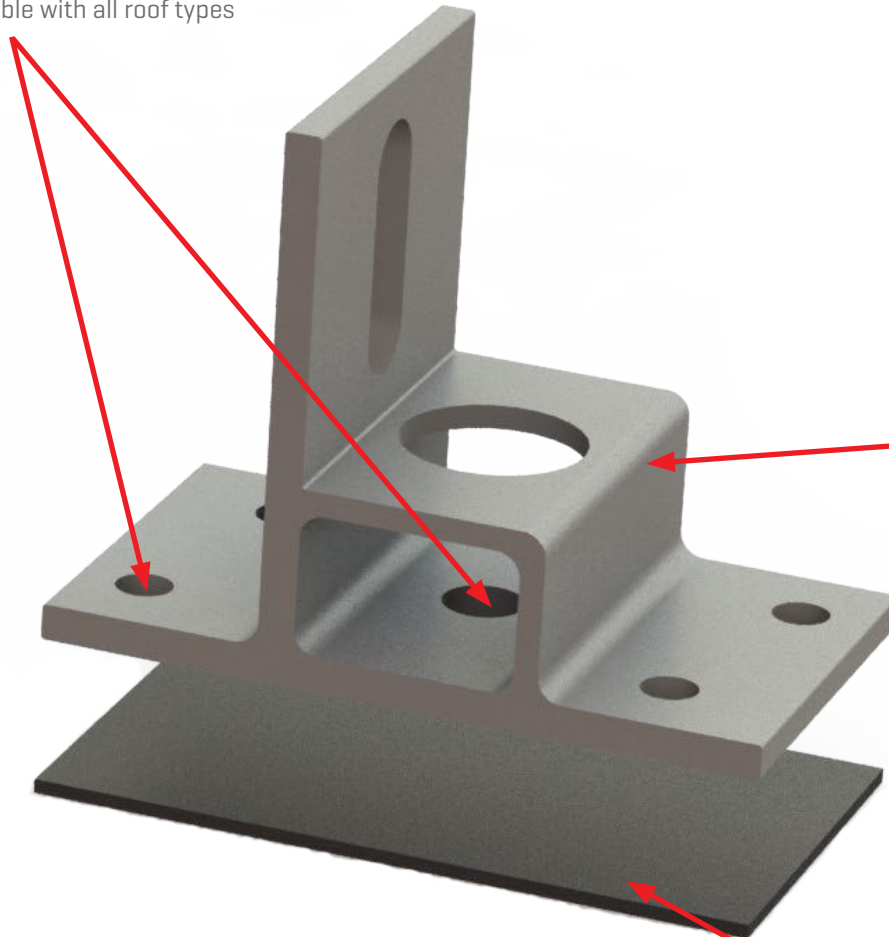

Rail Shelf

- ▶ Allows for easier rail support
- ▶ Aligns CrossRail T-Bolt channel

K2 EverSeal

- ▶ Pre-installed butyl flexible flashing
- ▶ 30+ years of proven water sealing technology
- ▶ TAS 100[A] and Wind Driven Rain tested and approved



K2 Flex Foot

TECHNICAL SHEET

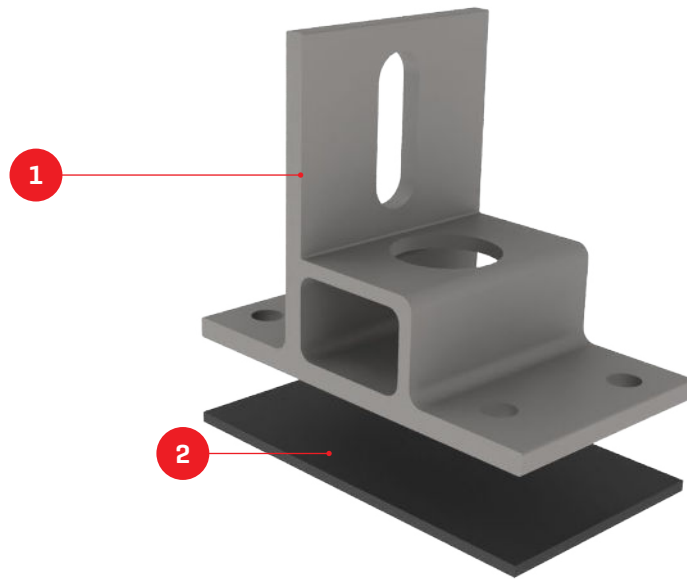

K2 Flex Foot

TECHNICAL SHEET

| Item Number | Description | Part Number |
|-------------|--------------|---|
| 1 | K2 Flex Foot | 4000718 K2 Flex Foot Kit, Mill w/EverSeal |
| 2 | K2 EverSeal | |

Technical Data

| K2 Flex Foot | |
|-----------------|---|
| Roof Type | Composition shingle, all flat roofs |
| Material | Aluminum with stainless steel hardware |
| Finish | Mill |
| Roof Connection | [4] M5 x 60 screws to deck or [1] 5/16" lag screw to rafter, 3/8" anchor for concrete |
| Code Compliance | UL 2703 |
| Compatibility | CrossRail 44-X, 48-X, 48-XL, 80 |

CONNECTING STRENGTH



Units: [in] mm

