

# GROUND MOUNT

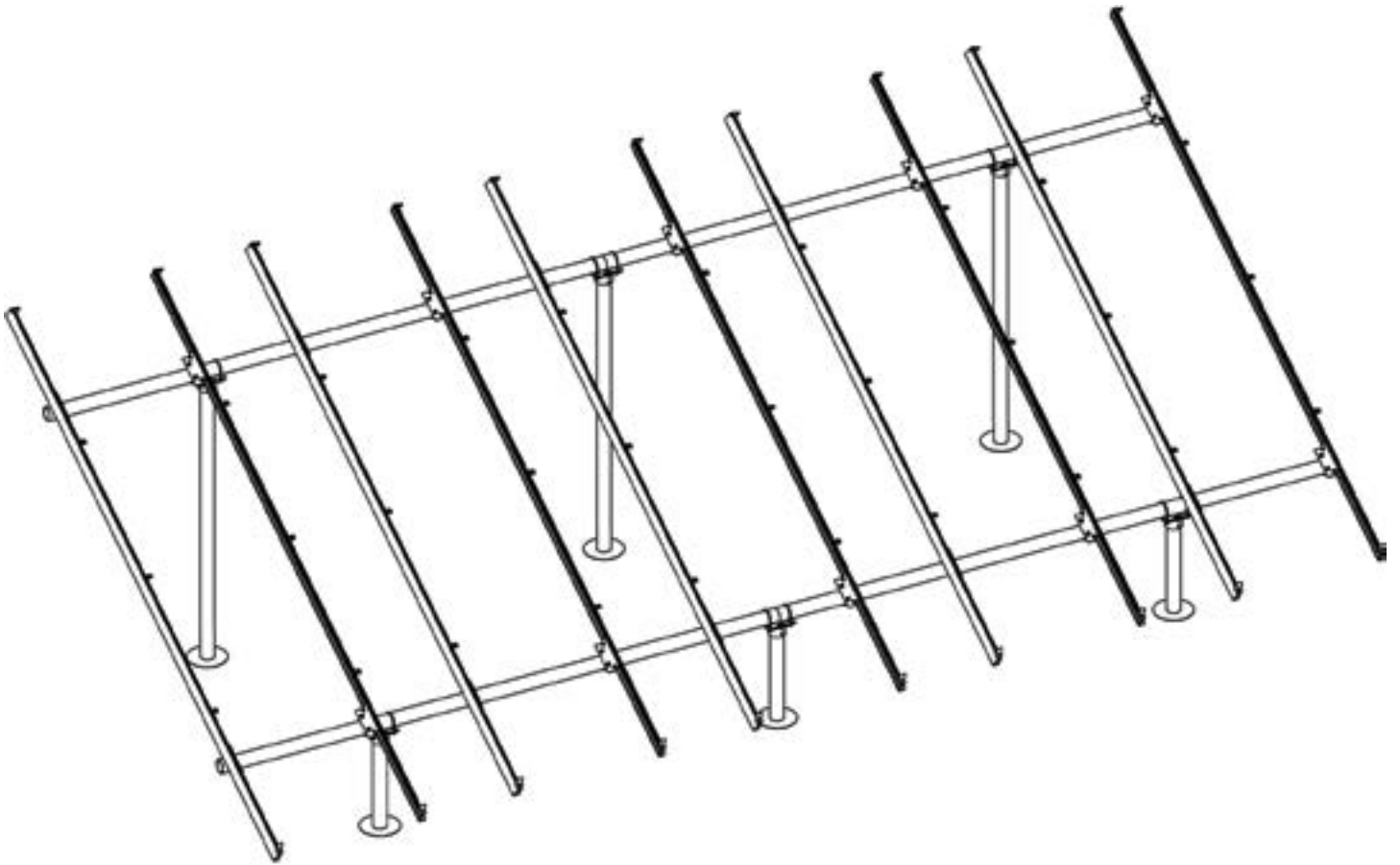

# CONTENTS

<b>DISCLAIMER</b>	<b>1</b>
<b>RATINGS</b>	<b>2</b>
<b>MARKINGS</b>	<b>2</b>
<b>CHECKLIST</b>	<b>3</b>
<b>1. BUILD BASE</b>	<b>4</b>
<b>1. BUILD BASE</b>	<b>5</b>
<b>2. CONNECT SUBSTRUCTURE</b>	<b>5</b>
<b>3. PLACE RAILS</b>	<b>6</b>
<b>4. SECURE LUGS</b>	<b>6</b>
<b>5. SECURE MODULES</b>	<b>7</b>
<b>CAMO</b>	<b>8</b>
<b>ELECTRICAL DIAGRAM</b>	<b>9</b>
<b>DIAGONAL BRACES (OPTIONAL)</b>	<b>10</b>
<b>END CAPS</b>	<b>10</b>
<b>WIRE CLIPS</b>	<b>10</b>
<b>SPLICING HORIZONTAL BEAMS</b>	<b>11</b>
<b>MICROINVERTER KITS</b>	<b>12</b>
<b>SYSTEMS USING MICROSTORAGE PRODUCTS</b>	<b>13</b>
<b>FRAMELESS MODULE KITS</b>	<b>13</b>
<b>MODULE COMPATIBILITY</b>	<b>14-20</b>
<b>FRAMLESS MODULE COMPATIBILITY</b>	<b>21</b>

## DISCLAIMER

This manual describes proper installation procedures and provides necessary standards required for product reliability. Warranty details are [available on website](#). All installers must thoroughly read this manual and have a clear understanding of the installation procedures prior to installation. Any installation or use of this product not in accord with or not authorized by this written instruction shall void any and all warranties, express or implied, on the product or the use of the product and may cause failure, property damage and personal injury. IronRidge is not liable for any unauthorized use. Install and use only with other IronRidge products to ensure proper fit and function.

### IT IS THE INSTALLER'S RESPONSIBILITY TO:

- Ensure safe installation of all electrical aspects of the array. All electrical installation and procedures should be conducted by a licensed and bonded electrician or solar contractor. Routine maintenance of a module or panel shall not involve breaking or disturbing the bonding path of the system. All work must comply with national, state and local installation procedures, product and safety standards.
- Comply with all applicable local or national building and fire codes, including any that may supersede this manual.
- Ensure all products are appropriate for the installation, environment, and array under the site's loading conditions.
- Use only IronRidge parts or parts recommended by IronRidge; substituting parts may void any applicable warranty.
- Review the [Design Assistant](#) and [Certification Letters](#) to confirm design specifications.
- Ensure provided information is accurate. Issues resulting from inaccurate information are the installer's responsibility.
- Validate foundation parameters prior to installation, as a local geotechnical report may be required to assess ground conditions. We recommend consulting with a local engineer familiar with local regulations and build site requirements, including soil conditions, terrain and load criteria. All parameters may impact foundation requirements.
- Ensure bare copper grounding wire does not contact aluminum and zinc-plated steel components, to prevent risk of galvanic corrosion.
- If loose components or loose fasteners are found during periodic inspection, re-tighten immediately. Any components showing signs of corrosion or damage that compromise safety shall be replaced immediately.
- Provide an appropriate method of direct-to-earth grounding according to the latest edition of the National Electrical Code, including NEC 250: Grounding and Bonding, and NEC 690: Solar Photovoltaic Systems.
- Disconnect AC power before servicing or removing modules, AC modules, microinverters and power optimizers.
- Review module manufacturer's documentation for compatibility and compliance with warranty terms and conditions.

## RATINGS

### UL 2703 LISTED



#5003225

### Conforms to STD UL 2703 Standard for Safety First Edition: Mounting Systems, Mounting Devices, Clamping/Retention Devices, and Ground Lugs for Use with Flat-Plate Photovoltaic Modules and Panels

- Scope of Evaluation includes bonding, grounding, mechanical loading, and fire classification
- Max Overcurrent Protective Device (OCPD) Rating: 40A
- Max Module Size: 30.5 ft<sup>2</sup>
- Module Orientation: Portrait or Landscape
- System Design Load Rating: 10 PSF downward, 5 PSF upward, 5 PSF lateral
- Actual system structural capacity including spans and cantilevers is defined by PE stamped [certification letters](#)
- CAMO Specific Design Load rating: 50 PSF downward, 50 PSF upward, 15 PSF lateral

### Certified to CSA TIL No. A-40 Photovoltaic Module Racking Systems

- Load Rating: 2400 PA [50 PSF]

### CLASS A SYSTEM FIRE RATING PER UL 2703

- Not Fire Rated

### STRUCTURAL CERTIFICATION

- Designed and Certified for Compliance with the International Building Code & ASCE/SEI-7

## MARKINGS

Product markings are located on the system's Rail Connectors.

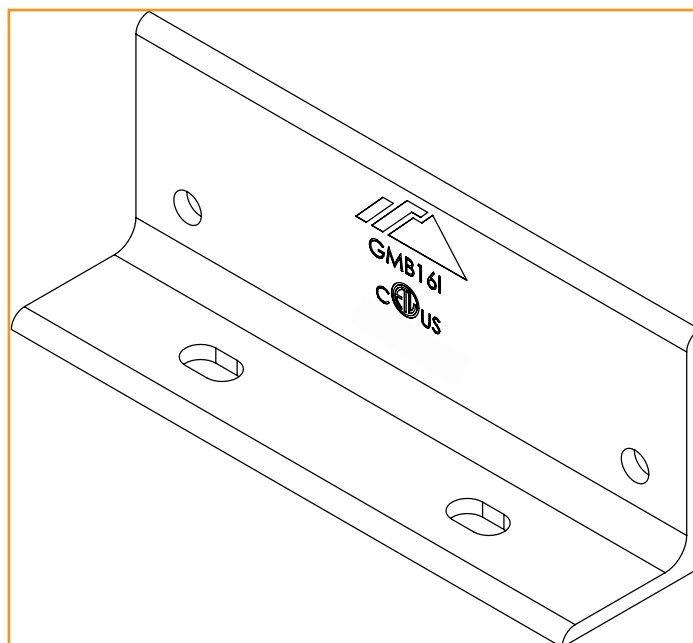

# CHECKLIST

## PRE-INSTALLATION

- Verify module compatibility. See [Page 14](#) for info.
- Purchase 2" or 3" Pipe or Mechanical Tubing

**Pipe:** 2" or 3" (NPS) ASTM A53 Grade B SCH 40 Pipe, galvanized to a min of ASTM A653 G90 or ASTM A123 G35.

**Mechanical Tubing:** 2.375" x 12 ga (O.D) or 3.500" x 8 ga (O.D.) Mechanical Tubing with one of the following Galvinizations (ASTM A1057).

- Allied Gatorshield
- Allied Flo-Coat Coating
- Wheatland ThunderCoat

## TOOLS REQUIRED

- Post Hole Digger or Powered Auger
- Socket Drive (7/16", 9/16", 15/16" and 1/2" Sockets)
- Torque Wrenches (0-300 in-lbs and 10-40 ft-lbs)
- Transit, String Line, or Laser Level
- 3/16" Allen Head

## TORQUE VALUES

Top Cap Set Screws (3/16" Allen Head)

- 2" or 3" NPS Schedule 40 Grade B Pipe: 20 ft-lbs
- 2.375" x 12 ga OD Mechanical Tubing: 11 ft-lbs
- 3.500" x 8 ga OD Mechanical Tubing: 16 ft-lbs
- For Ground Screw to Pipe Connection Hardware see [Page 5](#).
- Top Cap U-Bolt Nuts (9/16" Socket): 15 ft-lbs
- Rail Connector Bracket Nuts (9/16" Socket): 25 ft-lbs
- Rail Connector U-Bolt Nuts (9/16" Socket): 60 in-lbs
- Rail Grounding Lug Nut (7/16" Socket): 80 in-lbs
  - Rail Grounding Lug Terminal Screws (7/16" Socket): 20 in-lbs
- Module Grounding Lug Nut (3/8" Socket): 60 in-lbs
  - Module Grounding Lug Terminal Screws (1/2" Socket): 20 in-lbs
- Universal Fastening Objects (7/16" Socket): 80 in-lbs
- End Fastening Objects (7/16" Socket): 80 in-lbs
- Diagonal Brace Set Screws (1/2" Socket): 15 ft-lbs
- Diagonal Brace Bolts (1/2" Socket): 40 ft-lbs
- Microinverter Kit Nuts (7/16" Socket): 80 in-lbs

- If using previous version of: Integrated Grounding Mid Clamps, Grounding Lug and End Clamps please refer to Alternate Components Addendum (Version 2.2).
- If installing on a low slope roof please refer to Ground Mount for Flat Roof Applications Addendum (Version 4.40).
- Unless otherwise noted, all components have been evaluated for multiple use. They can be uninstalled and reinstalled in the same or new location.
- \*CAMO is not intended for installation on any island or within 3 miles from any coastline and 2 miles from saltwater bays and inlets. CAMOs installed in these regions will not be covered by the IronRidge Product Warranty. Refer to IronRidge Design Assistant for installation applicability.

## IRONRIDGE COMPONENTS

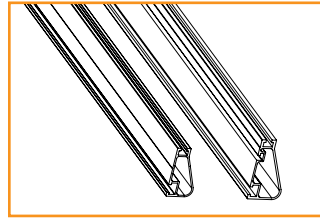

XR100 & XR1000 Rail



Rail Connector



Top Cap

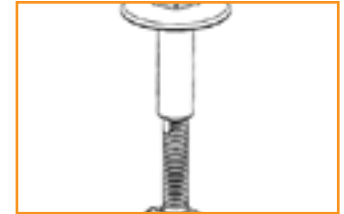

UFO (30-46mm)



Stopper Sleeve



CAMO\*

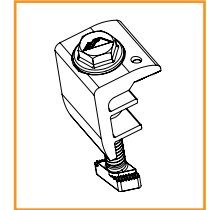

EFO  
(30-40mm)

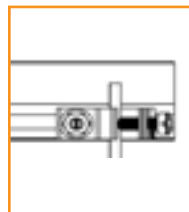

Rail Grounding  
Lug

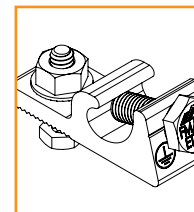

Module Grounding  
Lug



Microinverter Kit



Diagonal Brace



End Cap



Wire Clip

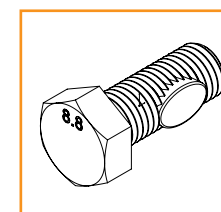

Hex Head Set  
Screw

## TESTED AND EVALUATED PIPE AND TUBE

Approved 2"	Approved 3"
<b>MECHANICAL TUBE 12 GA</b> <ul style="list-style-type: none"> <li>50 KSI YIELD STRENGTH</li> <li>GALVANIZED (ALLIED FLO-COAT, ALLIED GATORSHIELD OR WHEATLAND THUNDER COAT)</li> </ul> <p>TOP CAP SET SCREW INSTALL TORQUE: 11-FTLBS</p>	<b>MECHANICAL TUBE 8 GA</b> <ul style="list-style-type: none"> <li>45 KSI YIELD STRENGTH</li> <li>GALVANIZED (ALLIED FLO-COAT, ALLIED GATORSHIELD OR WHEATLAND THUNDER COAT)</li> </ul> <p>TOP CAP SET SCREW INSTALL TORQUE: 16-FTLBS</p>
<b>SCHEDULE 40 GR B PIPE</b> <ul style="list-style-type: none"> <li>ASTM A53 GR B</li> <li>35 KSI YIELD STRENGTH</li> <li>HOT DIPPED GALVANIZED</li> </ul> <p>TOP CAP SET SCREW INSTALL TORQUE: 20-FTLBS</p>	<b>SCHEDULE 40 GR B PIPE</b> <ul style="list-style-type: none"> <li>ASTM A53 GR B</li> <li>35 KSI YIELD STRENGTH</li> <li>HOT DIPPED GALVANIZED</li> </ul> <p>TOP CAP SET SCREW INSTALL TORQUE: 20-FTLBS</p>

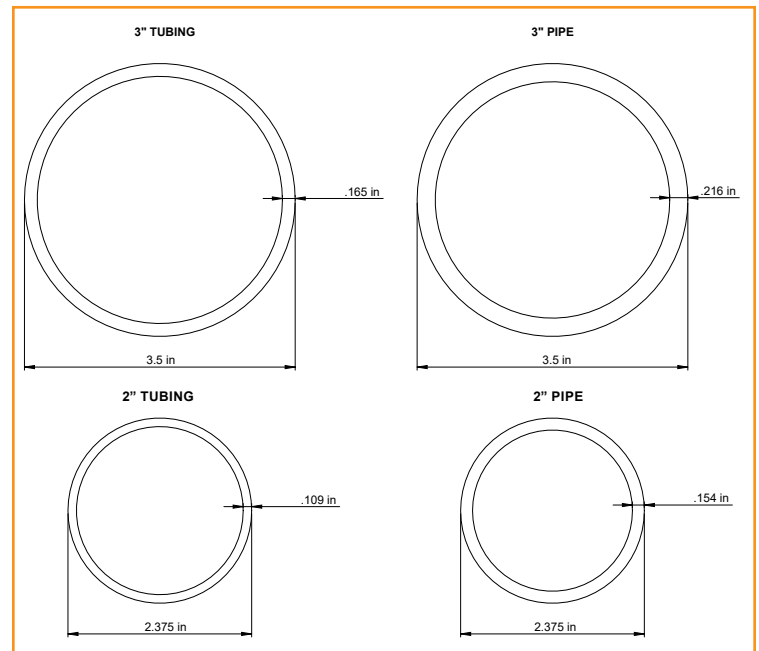

## 1. BUILD BASE

### A. MARK LOCATIONS

Establish pier locations. Once grid of pier locations has been set, verify all angles are square.

- Spacing varies with load conditions. Consult engineering specs.

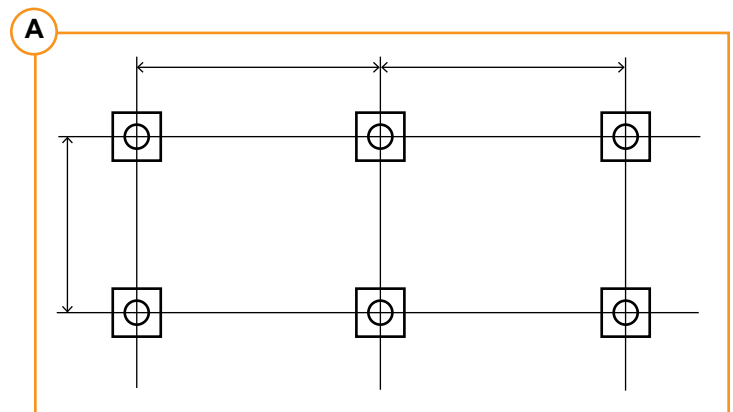

### B. POSITION PIERS CONCRETE FOUNDATIONS

Excavate the foundation holes. Insert vertical piers into foundation holes, and pour in concrete mixture. Ensure vertical piers are plumb, level, square, and placed in parallel rows. Level the tops so they are even.

- Brace piers until concrete foundation has cured.
- In some cases, cross bracing is required to provide extra support for piers. If required, install [Diagonal Braces](#) at this time.

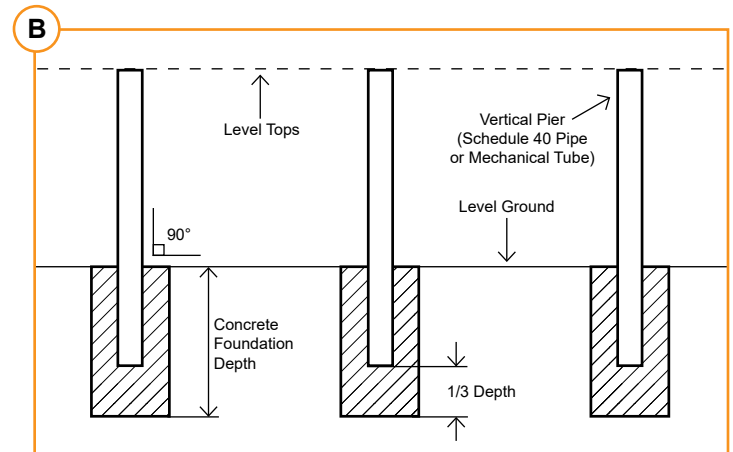

# 1. BUILD BASE (CONT.)

## GROUND SCREW FOUNDATIONS

Follow respective Ground Screw Manufacturer's installation methods for driving screws into soil. Insert vertical piers into ground screws, ensuring at least 22" of pier is inserted into ground screw.

### Tested and/or Evaluated Ground Screws

	2" System	3" System
Manufacturer Model #	American Ground Screw Model 3 76mm x 3(+) mm	American Ground Screw Model 3 102mm x 3.75(+) mm
	Krinner North America KSF G76	Krinner North America KSF G114
Set Screw Torque Specification	SCHD. 40: 90 ft-lb	SCHD. 40: 120 ft-lb
	Mech. Tubing: 75 ft-lb	Mech. Tubing: 90 ft-lb

- A minimum ground screw length of 1300mm must be used for either ground screw manufacturer. Longer lengths may be required in areas with high wind and snow loads or risk of freeze-thaw heaving. Check with your local jurisdiction for frost line embedment requirements.
- Hex Head Set Screw must be M16-2.0 x 40mm hot-dip galvanized bolts.

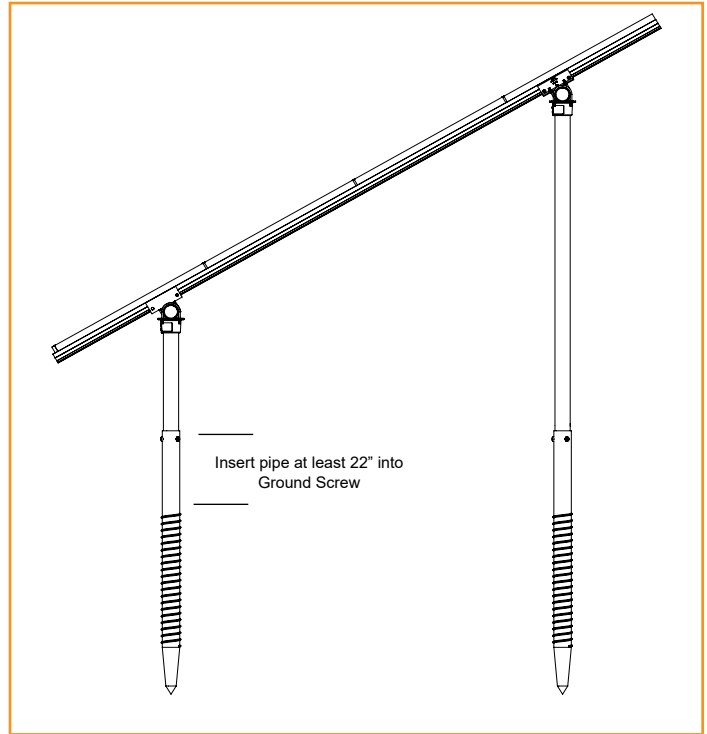

# 2. CONNECT SUBSTRUCTURE

## A. MOUNT TOP CAPS

Mount a Top Cap on each vertical pier. Wait to tighten set screws.

- If using [Diagonal Braces](#), install them prior to Top Caps.
- Do not install Top Caps on threaded pipe ends.

## B. LAY HORIZONTAL BEAMS

Set horizontal beams (Pipe or Mechanical Tubing) in Top Cap grooves. Attach with 3/8" U-bolts, Flange Nuts, Flat Washers and Lock Washers. Alternate each side when tightening to avoid warping U-bolts. Torque U-bolts to **15 ft-lbs** and align assembly.

Torque Top Cap set screws to **20 ft-lbs** for Schedule 40 Grade B Pipe, **11 ft-lbs** for 2.375" x 12 ga Mechanical Tubing, and **16 ft-lbs** for 3.500" x 8 ga Mechanical Tubing.

- To join more than one section of horizontal beams, see [Page 10](#).
- Ensure both U-bolts are installed on every Top Cap.

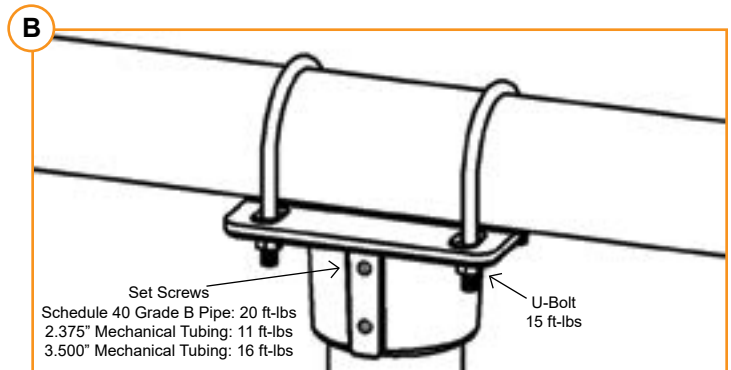
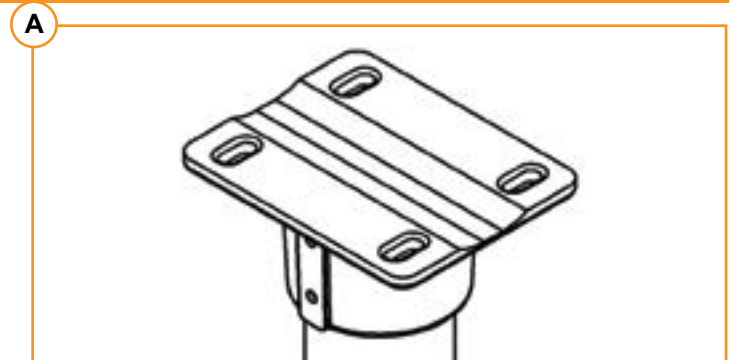

### 3. PLACE RAILS

#### A. ATTACH HARDWARE

On the ground, attach Rail Connector brackets to rail by sliding 3/8" bonding bolts into side slot. Space out to match vertical pier spacing. With brackets in place, finger tighten Flange Nuts onto bolts.

- Tape ends of rail, to keep bolts from sliding out while moving.
- Rail Connector should be located at least flush with pipe end.

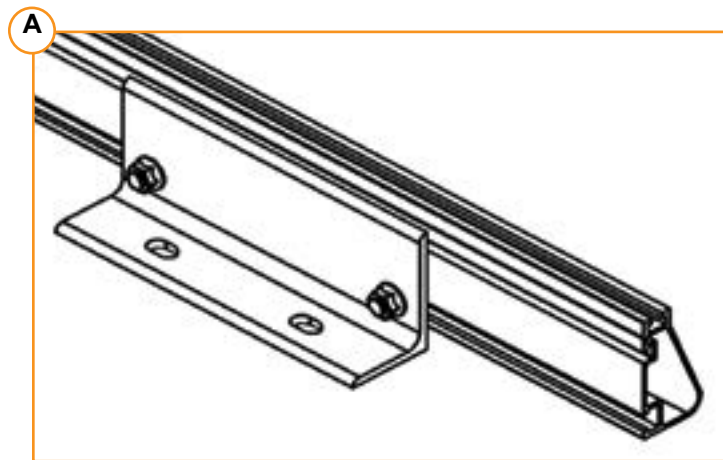

#### B. FASTEN CONNECTORS

Center Rails on horizontal beams, leaving equal distance on ends. Secure with Rail Connector hardware: 3/8"-16 U-bolts, Flange Nuts, Flat Washers and Lock Washers. Alternate each side when tightening U-bolts. Torque U-bolt nuts to **60 in-lbs** and bracket to **25 ft-lbs**.

- Spacing between rails should align with module manufacturer

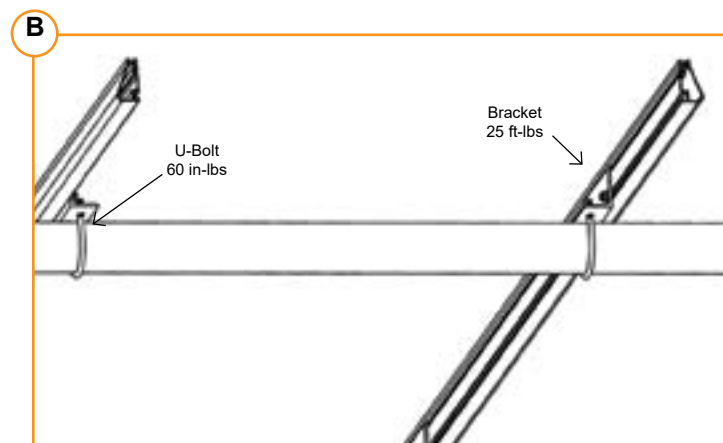

### 4. SECURE LUGS

#### Grounding Lugs

Only one Grounding Lug (Rail or Module) required per continuous subarray, regardless of subarray size (Unless frameless modules are used, see [Page 13](#)).

- Grounding Lugs are intended to for use with one solid or stranded copper wire, conductor size 10-4 AWG.

#### Rail Grounding Lug

Insert T-bolt in Top Rail slot and torque Hex Nut to **80 in-lbs**. Install a minimum 10 AWG solid copper or stranded grounding wire. Torque terminal screw to **20 in-lbs**.

- Rail Grounding Lugs can be installed anywhere along the Rail and in either orientation shown.

#### Module Grounding Lug

Insert Bolt through Module Manufacturer approved grounding location and torque Hex nut to **60 in-lbs**. One Module Grounding Lug may be installed to one module per continuous array. Install a minimum 10 AWG solid copper or stranded grounding wire. Torque terminal screw to **20 in-lbs**.

- Refer to module manufacturer manual for grounding instructions.

Rail Grounding Lug

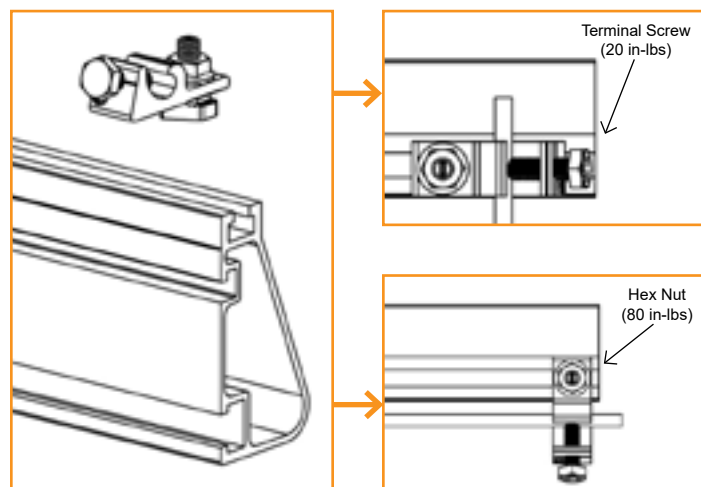

Module Grounding Lug

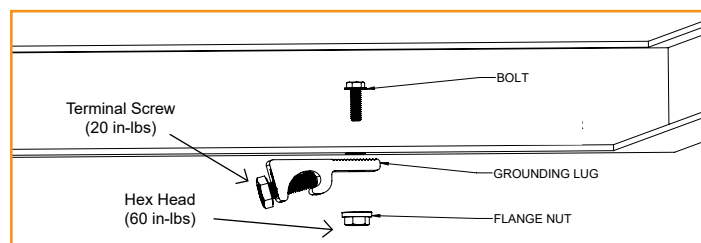

## 5. SECURE MODULES

### A. SECURE FIRST END

Place first module in position on rails, a minimum of 1" from rail ends. Snap Stopper Sleeves onto UFO. Fasten module to rail using the UFO or EFO, ensuring that the clamp is hooked over the top of the module. Torque to **80 in-lbs**.

- Ensure rails are square before placing modules.
- Hold Stopper Sleeves or EFO on end while torquing to prevent rotation.
- If using CAMO instead of UFO + Stopper Sleeve, refer to [Page 7](#) for CAMO installation procedure.
- UFO can be installed on modules 30 to 46mm.
- EFO can be installed on modules 30 to 40mm.

### B. SECURE NEXT MODULES

Place UFO into each rail, placing them flush against first module. Slide second module against UFO. Torque to **80 in-lbs**. Repeat for each following module.

- When reinstalling UFO, move modules a minimum of 1/16" so UFOs are in contact with a new section of module frame.
- When UFOs are loosened and re-tightened, ensure UFO T-bolt bottoms out in rail channel before re-torquing UFO to achieve full engagement between T-bolt and rail.
- If using Wire Clips, refer to [Page 9](#).

### C. SECURE LAST END

Place last module in position on rails, a minimum of 1" from rail ends. Snap Stopper Sleeves onto UFO. Secure UFO or EFO Clamps on rails, ensuring they are hooked over top of module. Torque to **80 in-lbs**.

- Hold Stopper Sleeves or EFO on end while torquing to prevent rotation.
- If using CAMO instead of UFO + Stopper Sleeve, refer to [Page 7](#) for CAMO installation procedure.

### D. REPEAT STEPS

Secure remaining module rows, leaving a minimum 3/8" gap between rows.

- If using End Caps, refer to [Page 9](#).

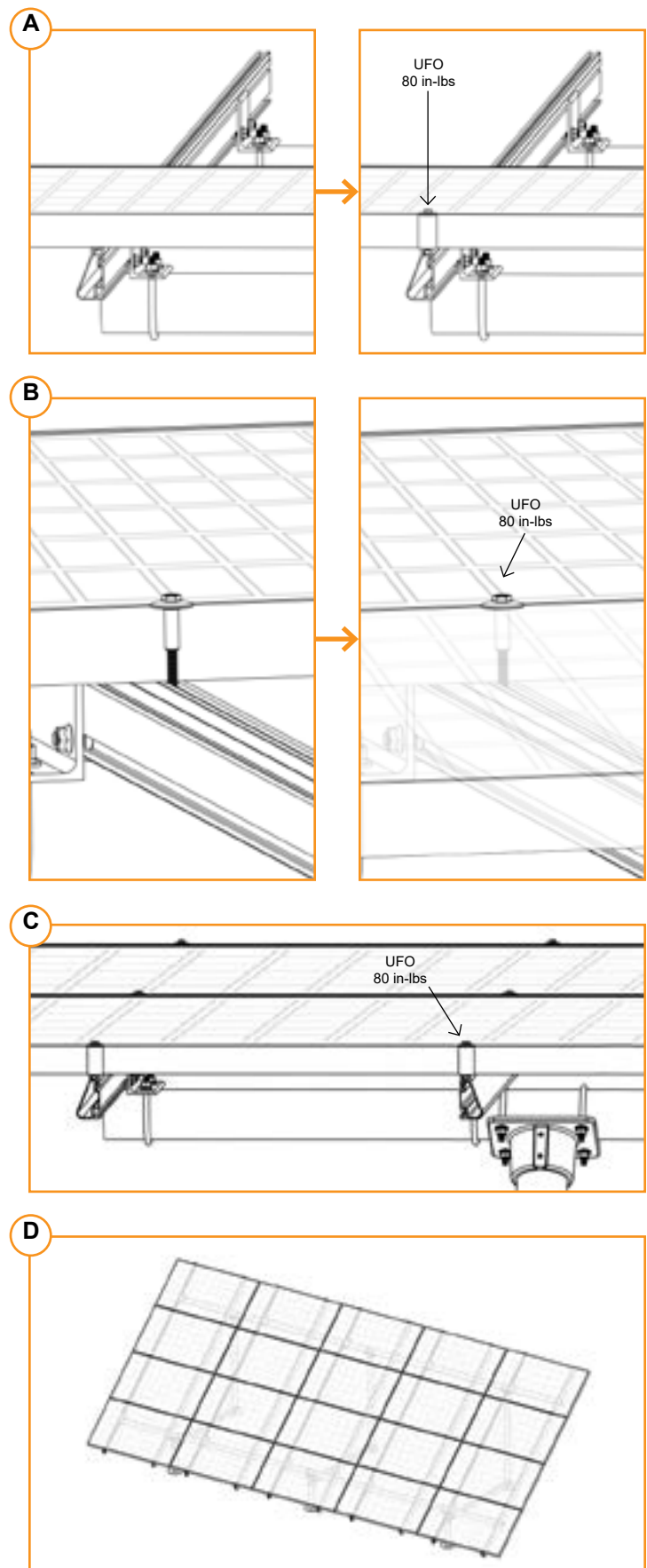

## A. SLIDE INTO RAIL

Slide CAMO into rail channel far enough to clear the module frame. CAMO requires 6" of clearance from end of rail.



## B. PLACE MODULE

Place module on rails (module cells not shown for clarity). When installing CAMO the module can overhang the rail no more than 1/4".



## C. PULL TOWARDS END

Pull CAMO towards rail ends, at 45 degree angle, so the bonding bolt contacts the module flange edge.



## D. SECURE TO FRAME

Rotate handle with an upwards motion until CAMO snaps into rail channel. Ensure CAMO bonding pins are fully seated on top of module frame.



## FRAME COMPATIBILITY

CAMO has been tested or evaluated with all modules listed in the Module Compatibility section having frames within the referenced dimensions. Be sure the specific module being used meets the dimension requirements.

- For module manufacturer specific compatibility where applicable, please refer to IronRidge online Design Assistant.
- CAMO is not intended for installation on any island or within 3 miles from any coastline and 2 miles from saltwater bays and inlets. CAMOs installed in these regions will not be covered by the IronRidge Product Warranty. Refer to IronRidge Design Assistant for installation applicability.

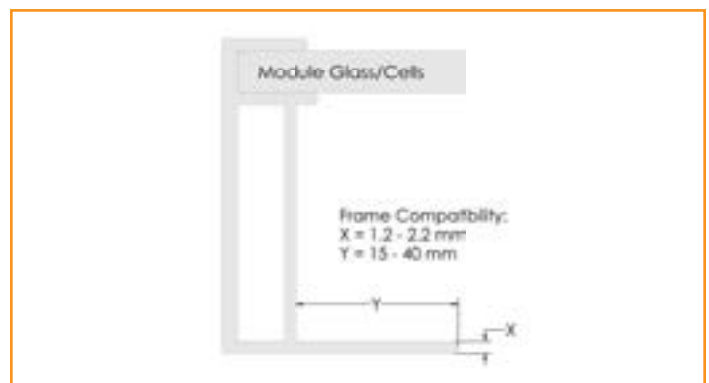

## ECLIPSE

A) Align Eclipse and slide into the top channel of the XR Rail far enough to clear the module frame.

- Note the head of the bolt should be facing towards the roof.
- It's easiest to orient the Eclipse so that the head of the bolt is on the flat side of the rail.

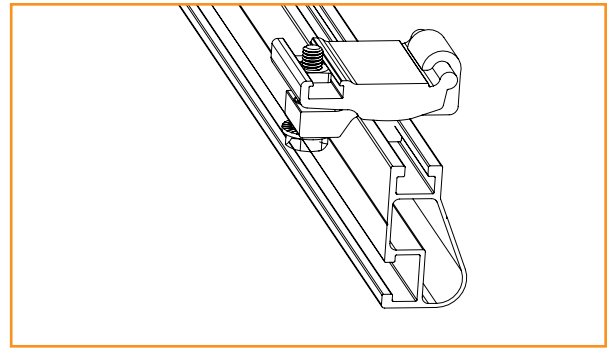

B) Place module on rails, then pull the Eclipse towards the module frame so the upper part of the Eclipse is resting on the module flange

- Because of XR's triangular profile, if the Eclipse is oriented so the head of the bolt is on the angled side, a crescent wrench will most likely be needed to tighten the clamp and secure the module.

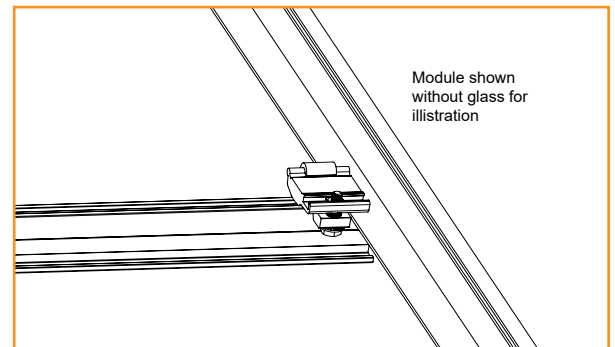

C) Secure the module by tightening the hex bolt with a 7/16" socket to 80 in-lb.

- IR Recommends using a cordless ratchet tool for optimal installation speed
- A ratcheting crescent wrench is also a good option.

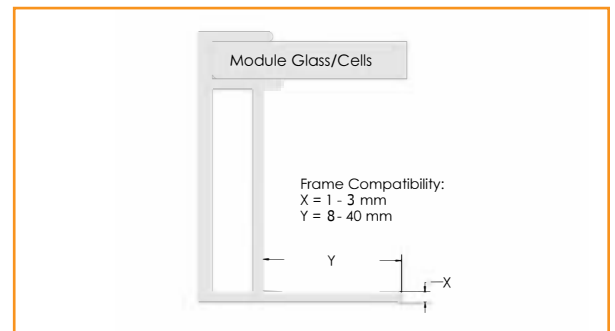

# ELECTRICAL DIAGRAM

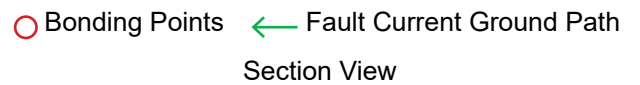
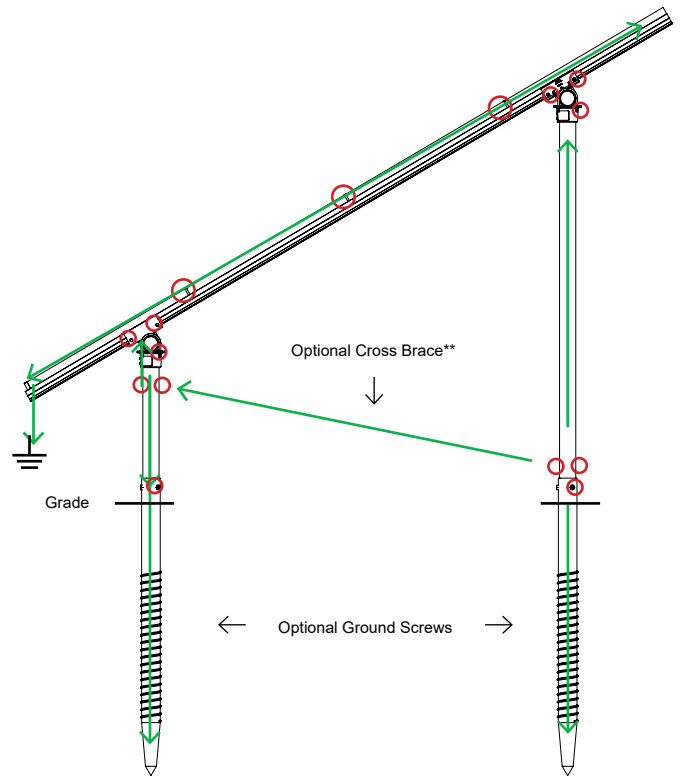
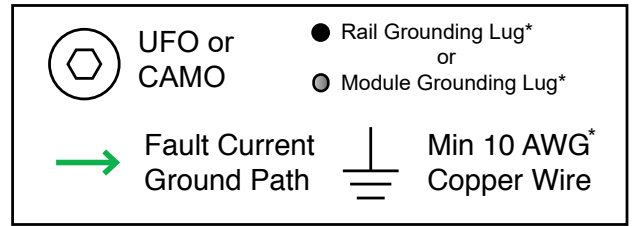
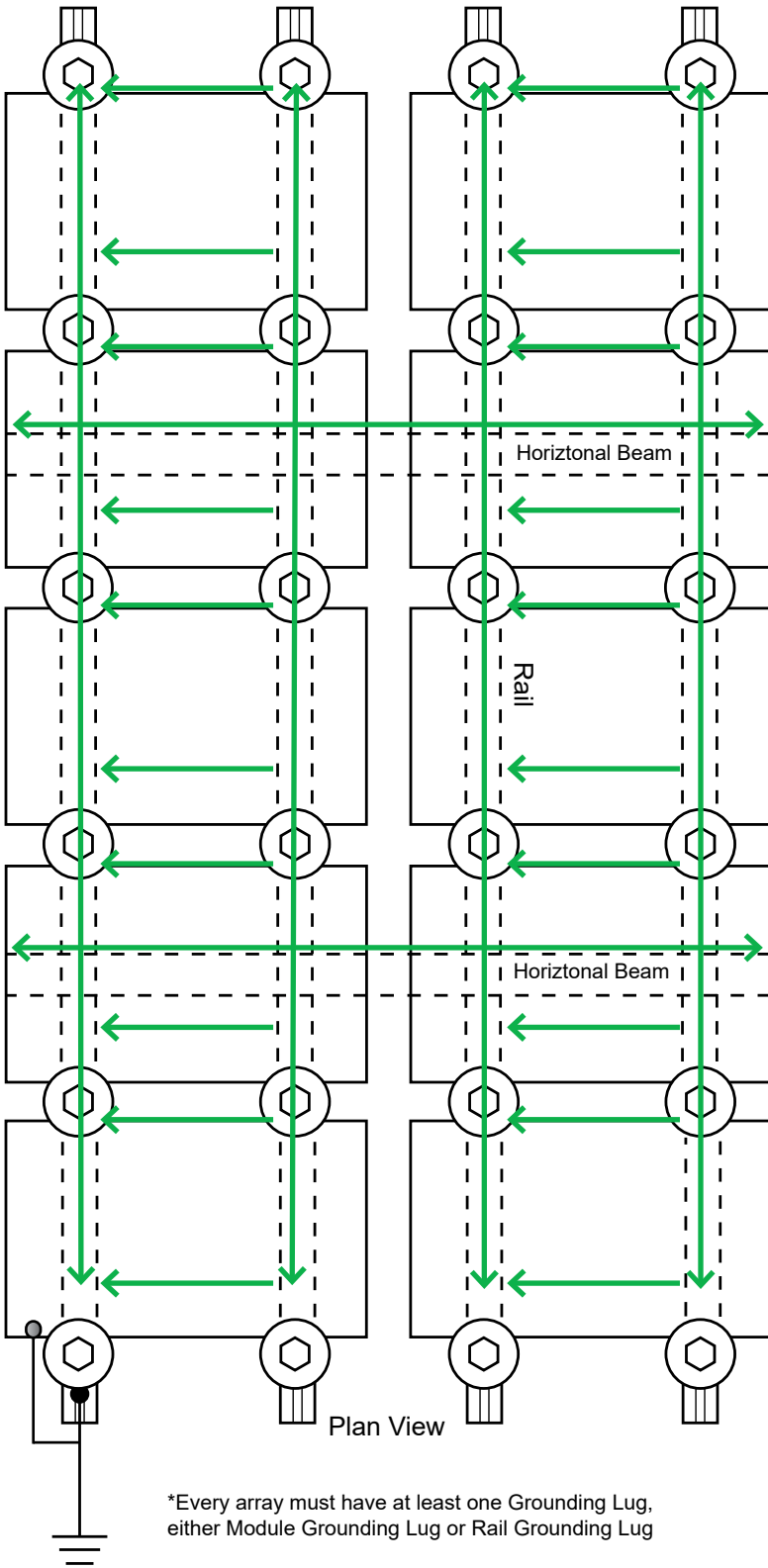

\*\*Cross Braces are optional for concrete foundation systems.

○ Bonding Points ← Fault Current Ground Path

● Rail Grounding Lug\*  
Or  
● Module Grounding Lug\*

## DIAGONAL BRACES (OPTIONAL)

Slide sleeve on north pier 2-3" above the ground (6" max). Attach Diagonal Brace to sleeve with 1/2" hardware.

Slide second sleeve up on south pier 2-3" below top cap (6" max). Raise Diagonal Brace to align holes in sleeve and brace. Attach hardware and raise sleeve to full extent.

Torque Diagonal Brace bolts to **40 ft-lbs**. Torque set screws to **15 ft-lbs**.

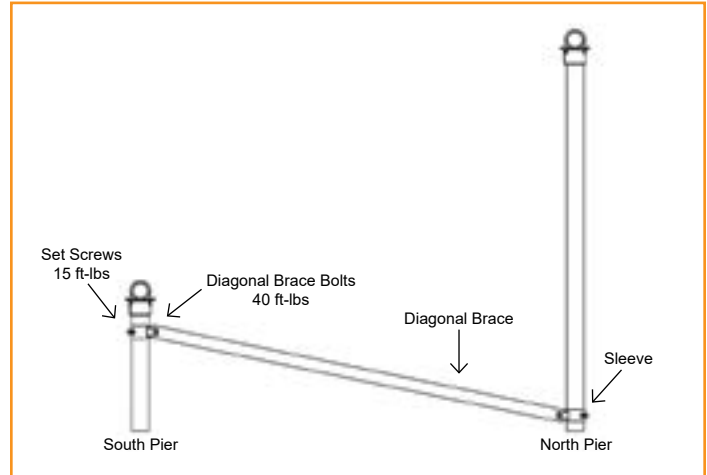

## END CAPS

End Caps add a completed look and keep debris and pests from collecting inside rail.

Firmly press End Cap onto rail end.

- End Caps come in sets of left and right. Check that the proper amount of each has been provided.
- For open-structure installations, you can use adhesive to secure the End Caps.

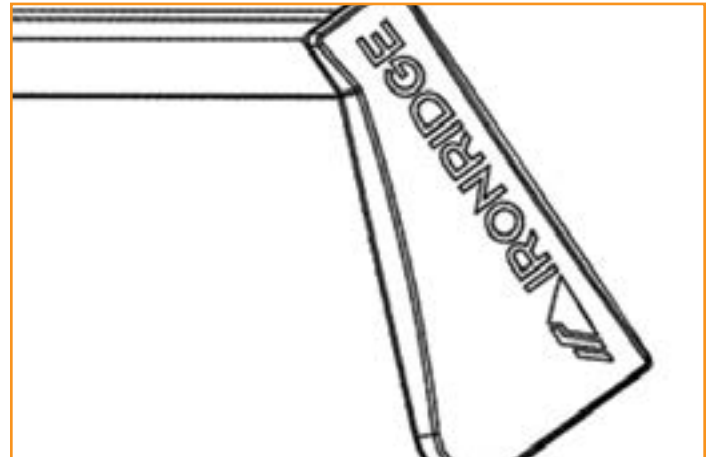

## WIRE CLIPS

Wire Clips offer a simple wire management solution.

Firmly press Wire Clip into top rail slot. Open clip and insert electrical wire accordingly. Close clip once complete.

- ☒ Wire Clip fits up to quantity 10 - 10 AWG PV Wire or equivalent bundled diameter.

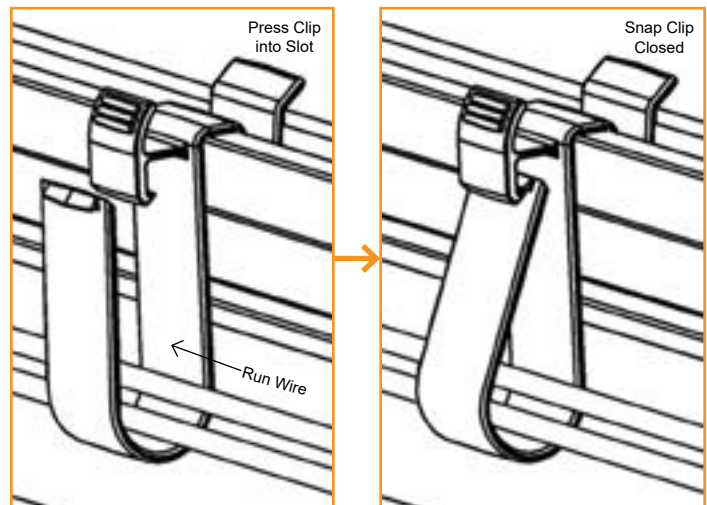

## SPLICING CROSS PIPE

The following instructions should be followed, when required, to join more than one section of horizontal beam together to ensure bonding is maintained throughout the system.

### A. MECHANICAL TUBING SPLICES

Mechanical tube splices shown in the table below shall be of equivalent Allied Flo-Coat, Allied Gatorshield or Wheatland ThunderCoat coating.

Mechanical Tube Size of the Structure	Splice Tube Size
2.375" OD, 12 Gauge	2.000" OD, 9 Gauge, Minimum 12" Long
3.500" OD, 8 Gauge	3.000" OD, 12 Gauge, Minimum 12" Long

Insert splice tube 6" into first section of cross tube and secure with 2 self-drilling screws (1/4"-14 x 3/4"), spacing them approximately 1.25" from end of pipe and approximately 3.50" apart, tightening screws to 9 ft-lbs.

Slide second section of cross tube over splice tube and secure with two more self-drilling screws. Tighten screws to 9 ft-lbs.

- Pre-drill 5/32" pilot holes through cross tube and splice tube for easier installation of self-drilling screws.

### B. SCHEDULE 40 GRADE B PIPE SPLICES

Use galvanized threaded pipe couplings that match the pipe size used for the structure. Threaded Schedule 40 Grade B Pipe must be used when splicing cross pipe together.

Fully thread coupling onto both sections of pipe being spliced together.

- Splice cannot be installed in the cantilever, center 1/3 of interior spans, or the outer 2/3 of end spans.

### C. HORIZONTAL PIPES CAN BE JOINED OVER AN INTERIOR TOP CAP WITH A MAXIMUM GAP OF 1/2"

- To avoid potential problems from the effects of thermal expansion, a maximum total continuous cross pipe length of 100 ft is recommended.

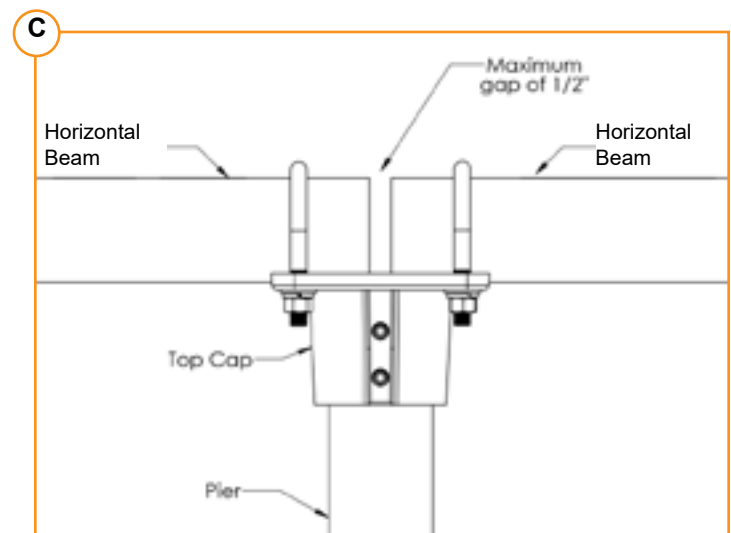
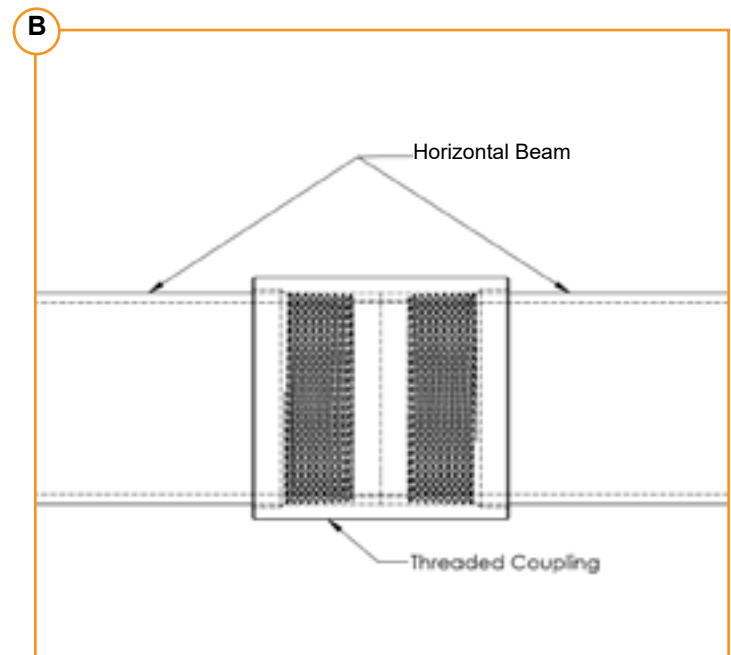
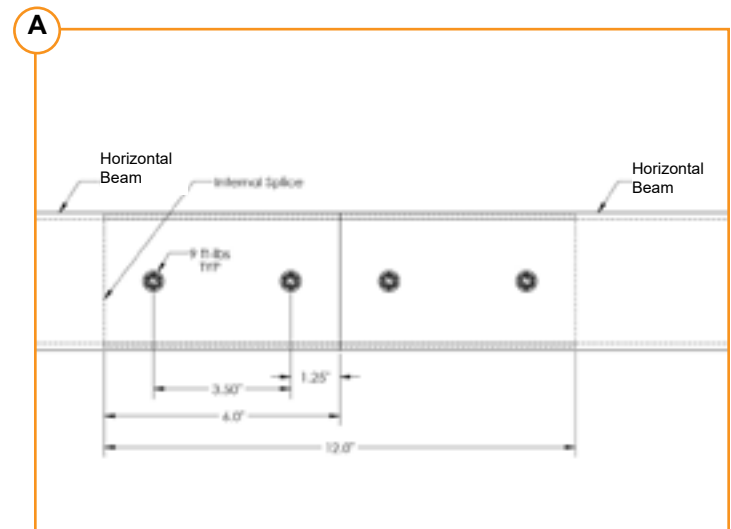

# MICROINVERTER KITS

Use IronRidge's Microinverter Kit to bond compatible microinverters and power optimizers to the racking system. Insert Microinverter Kit T-bolt into top rail slot. Place compatible microinverter or power optimizer into position and tighten hex nut to **80 in-lbs**.

➤ MLPE devices shall be installed near modules frames whenever possible.

AP Systems	DS3, QS1, QT2 and YC600
Darfon	MIG240, MIG300, G320, G640
Duracell	D350-M1, D350-M1A-xxx, D400-M1A-xxx, D600-M2A-xxx, D700-M2, D800-M2A-xxx, D1500-M4 Where "xxx" can be blank, 208A or 240A
Enphase	M250-72, 250-60, M215-60, C250-72, S230, S280, IQ 6, IQ 6+, IQ7, IQ 7A, IQ 7+, IQ7 PD, IQ 7X, Q Aggregator; IQ8-60, IQ8PLUS-72, IQ8A-72, IQ8H-208-72, IQ8H-240-72, IQ8M-72, may be followed by -2-US; IQ8H-3P-72-E-US or IQ8P-3P-72-E-US
Generac	S2502
Hoymiles	HMA-xxxYY-ZZ where "A" can be blank or S, xxx can be 300, 350, 400, 450, 500, 600, 700, 800, 900, 1000, 1200, 1500, 1600, 1800 or 2000; "YY" can be NT, 1T, 2T, 4T; and "ZZ" can be blank, NA or 208-NA
Lunar Energy	Maximizer
NEP Microinverters	BDM-xxx-yyy Where "xxx" can be 300, 300X2, 350, 400, 500, 550, 650, 800, 1000, 1200, 1600, 2000 and "yyy" can be blank, 208A or 240A
NEP Rapid Shutdown	PVG-1, PVG-2, PVG-3, PVG-4
SMA	RoofCommKit-P2-US, TS4-R Module Retrofit Kits (TS4-R-S, TS4-R-O, TS4-R-F)
Solar Edge	C651U, C652U, M1600, P300, P320, P340, P370, P400, P401, P405, P485, P505, P600, P700, P730, P750, P800p, P800s, P801, P850, P860, P950, P960, P1100, P1101, S440, S500, S500B, S650B, S1200, S1201, U650 and U650B
Tigo	Tigo Access Point (TAP) TS4-R-X (where X can be F, M, O, or S) TS4-R-X-DUO (where X can be M, O, or S) TS4-A-X (where X can be F, 2F, O, O-DUO, or S)
Yotta	DPI 208/480

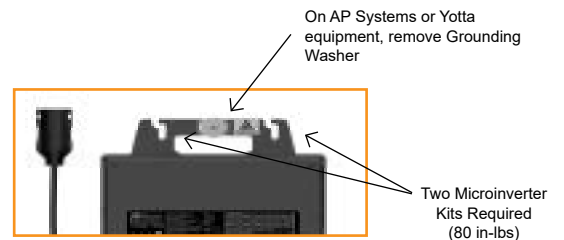
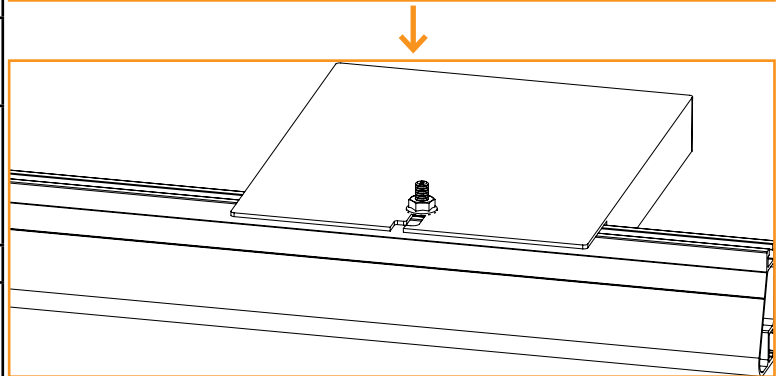
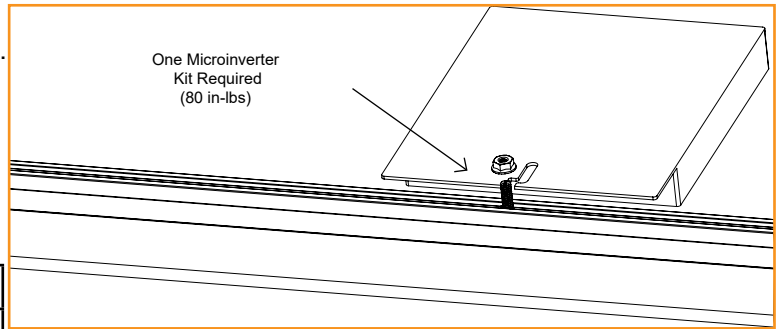

- Remove Grounding Washer on AP Systems QS1, QT2, DS3 and YC600 and Yotta inverters before installing to XR rails.
- Remove the Stainless Steel Clip on Tigo-"A" MLPE Devices before attaching to XR rails.
- Use the number of IronRidge Microinverter kits allowed by the MLPE mounting flange. Some will require 1 kit and others 2 kits.

Use IronRidge's Microinverter Kit to bond compatible microstorage devices to the racking system. Insert Microinverter Kit T-bolt into top rail slot. Place compatible microstorage into position and tighten hex nut to **80 in-lbs**.

### COMPATIBLE PRODUCTS

#### PHAZR

PHAZR Devices PHAZR-X, where X is 6-12.

- Running a separate equipment grounding conductor to the PHAZRs is not required.
- If installing in areas with ground snow loads greater than 40 psf and underneath a module, install PHAZR devices as close as possible to module frame edge.
- Use the number of IronRidge Microinverter kits allowed by the microstorage mounting flange. Some will require 1 kit and others 2 kits.

#### Yotta

Solar Leaf SL-1000

- Mount Solar Leaf using Solar Leaf Mounting Bracket 310-00080
- Attach Mounting Bracket to XR100 or XR1000 Rail with Ironridge Bonding Hardware BHW-TB 02-A1 or HBW-SQ-02-A1
- Torque Bonding hardware nut to 21 ft-lbs
- Refer to Solar Leaf SL-1000 Ironridge Supplemental Manual for full instructions

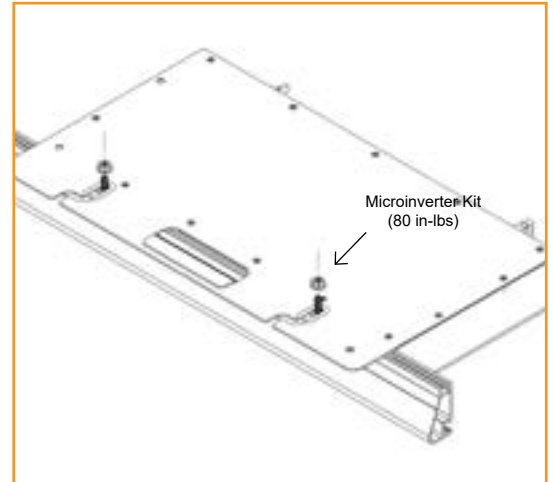

## MODULE COMPATIBILITY

The Ground Mount System has been tested and evaluated to UL 2703 for bonding, grounding, mechanical loading and fire classification, and may be used to ground and/or mount PV modules listed to UL 1703 or UL 61730. A list of approved modules is included below. Unless otherwise noted, “xxx” refers to the module power rating and both black and silver frames are included in the certification.

Framed Module List	
Make	Models
Adani	Adani modules with 30, 35 and 40 mm frames ASX-Y-ZZ-xxx Where "X" can be B, M or P, "Y" can be 6, 7 or M10 and "ZZ" can be blank, 144, PERC, B-PERC, or AB-PERC
AIONRISE	AIONRISE modules with 35 and 40 mm frames AIONyyG1-xxx Where "yy" can be 60 or 72
Amerisolar	Amerisolar modules with 35 and 40 mm frames AS-bYxxxZ Where "b" can be 5 or 6; "Y" can be M, P, M27, P27, M30, or P30; and "Z" can be blank, W or WB
Aptos Solar	Aptos modules with 35 and 40 mm frames DNA-yy-zzaa-xxxbb Where "yy" can be 108, 120 or 144; "zz" can be MF or BF; "aa" can be 10, 23 or 26; and "bb" can be blank or W-DG
Astronergy Solar	Astronergy modules with 30, 35 and 40 mm frames aaSMbbyyC/zz-xxx Where "aa" can be CH or A; "bb" can be 60, 66, or 72; "yy" can be blank, 10 or 12; "C" can be M, P, M(BL), M-HC, M(BL)-HC, P-HC, M(DG), M(DGT) or N(DG); and "zz" can be blank, HV, F-B, or F-BH
ASUN	ASUN modules with 35 and 40 mm frames ASUN-xxx-YYZZ-aa Where "YY" can be 60 or 72; "ZZ" can be M, or MH5; and "aa" can be blank or BB
Auxin	Auxin modules with 35 and 40 mm frames AXNCyZAxxxB Where "C" can be 6, 10 or G1; "y" can be M or P; "z" can be blank, 08, 09, 610, 11, or 612; and "A" can be F, M or T; and "B" can be blank, A, B, C or W
Axitec	Axitec Modules with 30, 35 and 40 mm frames AC-xxxY/aaZZb Where "Y" can be M, P, MB, MBT or MH; "aa" can be blank, 125- or 156-; "ZZ" can be 54, 60, 72, 108, 120, or 144; "b" can be S, X, V, VB, XV, or MX
Big Shine Solar	Big Shine Solar modules with 35mm frames BSExxxN-144BMH-DG
Bluesun Solar	Bluesun modules with 30 and 35 mm frames BSMxxxY-AAA Where "Y" can be M or M10; and "AAA" can be 54HPH, 60HPH or 72HBD
Boviet	Boviet modules with 35 and 40 mm frames BVMZZaaYY-xxxBcc Where "ZZ" can be 66 or 76; "aa" can be 9, 10 or 12; "YY" is M or P; and "B" can be blank, L or S; and "cc" can be blank, H, H-BF, H-BF-DG, H-HC, H-HC-BF, H-HC-BF-DG, HC-BF or HC-BF-DG
BYD	BYD modules with 30 and 35 mm frames BYDxxxAY-ZZ Where "A" can be M6, P6, MH, MLB, MLT, NLB or PH; "Y" can be C or K; and "ZZ" can be 30 or 36
Canadian Solar	Canadian Solar modules with 30, 32, 35 and 40 mm frames CSbY-xxxZ Where "b" can be 1, 3, 6, 6.1, 6.2 or 7; "Y" can be H, K, L, N, P, R, U, V, W, X, Y, -48TM, -54TM, -66TB or -72TB; and "Z" can be H, HP, M, P, T, MS, PX, M-SD, P-AG, P-SD, MB-AG, PB-AG, MS-AG, MS-HL, MS-SD or TB-AG
CertainTeed	CertainTeed modules with 30, 35 and 40 mm frames CTBBxxxYZZ-AA Where "BB" can be blank or M10; "Y" can be M, P, or HC; "ZZ" can be 00, 01, 10, or 11; and "AA" can be 01, 02, 03, 04, 06, 08 or 09

## MODULE COMPATIBILITY

Crossroads Solar	Crossroads Solar modules with 40 mm frames Crossroads Solar xxx
CSUN	Csun modules with 35 and 40 mm frames YYxxx-zzAbb Where "YY" is CSUN or SST; "zz" is blank, 60, or 72; and "A" is blank, P, M or MM; "bb" is blank, BB, 5BB, BW, or ROOF
Dehui	Dehui modules with 30, 35 and 40 mm frames DH-MYYYYZ-xxx Where "YYY" can be 760, 772, 860, 872; and "Z" can be B, F or W
Ecosolargy	Ecosolargy modules with 35 and 40 mm frames ECOxxxYzzA-bbD Where "Y" can be A, H, S, or T; "zz" can be 125 or 156; "A" can be M or P; "bb" can be 60 or 72; and "D" can be blank or B
Emmvee	Emmvee modules with 35 mm frames Exxx-YYZZZ-A Where "YY" can be M, P, HCM, HCMW, HCBG, HCBT; "ZZZ" can be 72, 120 or 144; and "A" can be blank or B
ET Solar (EliTe Solar)	ET Solar modules with 30, 33, 35 and 40 mm frames ET-YZZZxxxAA Where "Y" can be P, L, M, N or NR; "ZZZ" can be 48TBH, 660, 660BH, 672, 672BH, 754BH, 760BH, 766BH, 772BH, 760TBH, 766TBH, 772TBH or 848TBH; and "AA" can be GB, GL, TB, TW, WB, WW, BB, WBG, WWG, WBAC, WBCO, WWCO, WWBCO or BBAC
Flex	Flex modules with 35 and 40 mm frames FXS-xxxYY-ZZ; Where "YY" can be BB or BC; and "ZZ" can be MAA1B, MAA1W, MAB1W, SAA1B, SAA1W, SAC1B, SAC1W, SAD1W, SBA1B, SBA1W, SBC1B, or SBC1W
Freedom Forever	Freedom Forever modules with 35 mm frames FF-MPa-BBB-xxx Where "a" can be blank or 1
Freevolt	Freevolt modules with 35 mm frames ECP-PVGRAF-144HC-xxx
GCL	GCL modules with 35 mm and 40 mm frames GCL-ab/YY xxx Where "a" can be M or P; "b" can be 3 or 6; and "YY" can be 60, 72, 72H, or 72DH
GigaWatt Solar	Gigawatt modules with 40 mm frames GWxxxYY Where "YY" can be either PB or MB
Goldi	Goldi modules with 35 mm frames GS10-Byyy-zz-xxx Where "yyy" can be 108 or 144; and "zz" can be GF or TF
Grape Solar	Grape modules with 35 mm frames GS-M120-xxx-FAB1
GreenWatts Solar	GreenWatts modules with 30 and 35mm frames HSYY-A-xxx-ZZ Where "YY" can be 54, 60, 66, 72 or 78; "A" can be blank or F; and "ZZ" can be MN or BOB
Hansol	Hansol modules with 30, 35 and 40 mm frames HSxxxYY-zz Where "S" can be A or S; "YY" can be AA, AD, PB, PD, PE, TB, TD, UB, UD, UE or XD; and "zz" can be AH2, AN1, AN3, AN4, HH2, HV1, JH2, GNEA0 or NNEA0
Hanwa Solar	Hanwha Solar modules with 40 mm frames HSLaaP6-YY-1-xxxZ Where "aa" can be either 60 or 72; "YY" can be PA or PB; and "Z" can be blank or B

## MODULE COMPATIBILITY

Heliene	<p>Heliene modules with 35 and 40 mm frames YYZZxxxA Where "YY" can be 36, 60, 72, 96, 108, 120, 132, 144 or 156; "ZZ" can be HC, M, P, or MBLK; and "A" can be blank, HomePV, Bifacial, M10-SL, M10-SL-BLK, M10 TPC SL, M10 Bifacial, M10 SL-Bifacial or M10 TPC SL Bifacial</p>
HT-SAAE	<p>HT-SAAE modules with 35 and 40 mm frames HTyy-aaaZ-xxx Where "yy" can be 60, 66, 72 or 78, "aaa" can be 18, 156 or 166, "Z" can be M, P, M-C, P-C, M(S), M(VS), M(V), P(V), M(V)-C, P(V)-C, or X</p>
Hyperion Solar (Runergy)	<p>Hyperion modules with 30 and 35 mm frames HY-DHzzzA8-xxxB Where "zzz" can be 108 or 144; "A" can be N or P; and "B" can be blank or B</p>
Hyundai	<p>Hyundai modules with 30, 32, 33, 35 and 40 mm frames HiY-SxxxZZ Where "Y" can be A, D, N or S; "S" can be M, S or T; and "ZZ" can be GI, HG, HI, KI, MI, MF, MG, NF(BK), NJ, OJ, PI, RI, RG, RG(BF), RG(BK), SG, TI, TG, YH(BK) or XG(BK)</p>
Illuminate USA	<p>Illuminate USA Modules with 30 mm frames IL5-72HBD-xxxM</p>
Itek	<p>Itek Modules with 40 mm frames IT-xxx-YY Where "YY" can be blank, HE, or SE, or SE72</p>
JA Solar	<p>JA Solar modules with 30, 35 and 40 mm frames JAyyzz-bbww-xxx/aa Where "yy" can be M, P, M6 or P6; "zz" can be blank, (K), (L), (R), (V), (BK), (FA), (TG), (FA)(R), (L)(BK), (L)(TG), (R)(BK), (R)(TG), (V)(BK), (BK)(TG), or (L)(BK)(TG); "bb" can be 48, 54, 60, 66, 72 or 78; "ww" can be D09, D10, D20, D30, S01, S02, S03, S06, S09, S10, S12, S17, S20, S30 or S31; and "aa" can be BP, MB, MR, SI, SC, PR, 3BB, 4BB, 4BB/RE, 5BB</p>
Jakson Solar	<p>Jakson Solar modules with 35mm frames JH-xxxYY Where "YY" can be BB or BT</p>
Jinko	<p>Jinko modules with 30, 35 and 40 mm frames JKMYxxxZZ-aa Where "Y" can either be blank or S; "ZZ" can be M, N, P, or PP; and "aa" can be blank, 54HL4-B, 60, 60B, 60H, 60L, 60BL, 60HL, 60HB, 60HBL, 6HBL-EP, 60-J4, 60B-J4, 60B-EP, 60(Plus), 60-V, 60-MX, 6RL3, 6RL3-B, 6TL3-B, 66HL4M-BDV, 7RL3-V, 7RL3-TV, 72, 72B, 72-J4, 72B-J4, 72(Plus), 72-V, 72H-V, 72L-V, 72HL-V, 72HBL-V, 72HL4-V, 72HL4-BDV, 72HL4-TV, 72-MX, 72H-BDVP, 72HL-TV, 72HL-V-MX3 or 72HL4-BDX</p>
KB Solar	<p>KB Solar modules with 35 mm frames KBS-xxx-Mono-YY Where "YY" can be blank or BF</p>
Kyocera	<p>Kyocera Modules KYxxxZZ-AA Where "Y" can be D or U; "ZZ" can be blank, GX, or SX; and "AA" can be LPU, LFU, UPU, LPS, LPB, LFB, LFBS, LFB2, LPB2, 3AC, 3BC, 3FC, 4AC, 4BC, 4FC, 4UC, 5AC, 5BC, 5FC, 5UC, 6BC, 6FC, 8BC, 6MCA, or 6MPA</p>
LA Solar	<p>LA Solar modules with 35 mm frames LSxxxYY Where "YY" can be BF, BL, BLA, HC or ST</p>
LG	<p>LG modules with 35 and 40 mm frames LGxxxYaZ-bb Where "Y" can be A, E, M, N, Q, S; "a" can be A, 1, 2 or 3 "Z" can be C, K, T, or W; and "bb" can be A3, A5, A6, B3, B6, E6, E6.AW5, G3, G4, J5, K4, L5, N5, V5, V6</p>
Longi	<p>Longi modules with 30, 35 and 40 mm frames LRa-YYZZ-xxxM Where "a" can be 4, 5, 6, 7 or 8; "YY" can be blank, 54, 60, 66, or 72; and "ZZ" can be blank, BK, BP, HV, PB, PE, PH, HBD, HGD, HIB, HIH, HPB, HPH, HIBD, HABB, HABD or HGBB</p>

## MODULE COMPATIBILITY

Magnus Green Solar	Magnus Green Solar modules with 35 mm frames MGS-xxxW-yyy-M10 Where "yyy" can be blank, M54H, M60H or M72H
Maxeon	Maxeon modules with 35, 40 and 46 mm frames SPR-AAAY-xxx-zzz Where "AAA" can be MAX, P or X; "Y" can be 3, 5, 6, 7, 21 or 22; and "zzz" can be blank, R, BLK, BLK-R, COM or UPP
Meyer Burger	Meyer Burger Modules with 35 mm frames Meyer Burger Black, White or Glass
Mission Solar (mSolar)	Mission Solar modules with 30, 33, 35 and 40 mm frames YYYYbb-xxxZZaa Where "YYY" can be MSI, MSE, TXI or TXS; "bb" can be blank, 6, 10 or 60A; "ZZ" can be blank, HN, HT, MM, SE, SO, SQ, SR, SX, TS, 108, 120 or 144; and "aa" can be blank, 0B, 2B, BB, BW, 1J, 4G, 4J, 4S, 4T, 5K, 5R, 5T, 60, 6J, 6S, 6W, 6Z, 8K, 8T, 9R, 9S or 9Z
Mitrex	Mitrex modules with 30 and 40 mm frames Mxxx-XYZ Where "X" can be A, B, I or L; "Y" can be 1 or 3; and "Z" can be F or H
Mitsubishi	Mitsubishi modules PV-MYYxxxZZ Where "YY" can be LE or JE; and "ZZ" can be either HD, HD2, or FB
Moltech	IM and XS series modules with 40 mm frames
Navitas	Navitas Modules with 35 mm frames NSMxxx-yyy Where "yyy" can be 120, 132 or 144
Next Energy Alliance	Next Energy Alliance modules with 35 and 40 mm frames yyNEA-xxxZZ where "yy" can be blank or US; "ZZ" can be M, MB or M-60
NE Solar	NE Solar modules with 30, 35 and 40 mm frames NESExxx-zzAAX-yy Where "zz" can be 54, 60 or 72; "AA" can be MH or TH; "X" can be blank or B; and "yy" can be M6 or M10
Neo Solar Power	Neo Solar Power modules with 35 mm frames D6YxxxZZaa Where "Y" can be M or P; "ZZ" can be B3A, B4A, E3A, E4A, H3A, H4A; and "aa" can be blank, (TF), ME or ME (TF)
Panasonic (HIT)	Panasonic modules with 35 and 40 mm frames VBHNxxxYYzza Where "YY" can be either KA, RA, SA or ZA; "zz" can be either 01, 02, 03, 04, 06, 06B, 11, 11B, 15, 15B, 16, 16B, 17, or 18; and "A" can be blank, E, G, or N
Panasonic (EverVolt)	Panasonic modules with 30 mm frames EVPVxxxA Where "A" can be blank or H, K, HK, HK2 or PK
Peimar	Peimar modules with 40 mm frames SbxxxYzz Where "b" can be G, M or P; "Y" can be M or P; and "zz" can be blank, (BF) or (FB)
Philadelphia Solar	Philadelphia modules with 30, 35 and 40 mm frames PS-YzzAA-xxxW Where "Y" can be M, MNB, MNG or P; "zz" can be 60, 72, 108, 132, 144 or 156; "AA" can be blank, (BF), (HC), (HCBF) or (HCBF)-GG; and "W" can be blank or W
Phono Solar	Phono Solar modules with 30, 35 and 40 mm frames PSxxxY-ZZ/A Where "Y" can be M, M1, MH, M1H, M4, M4H, M5GF, M5GFH, M6, M6H, M8, M8H, M8GF, M8GFH or P; "ZZ" can be 18, 20 or 24; and "A" can be F, T, TH, THB, TNH, U, UH, UHB, VH or VHB
Prism Solar	Prism Solar modules with 35 mm frames PST-xxxW-M72Y Where "Y" can be H, HB or HBI

## MODULE COMPATIBILITY

Q CELLS	<p>Q CELLS Modules with 30, 32, 35, 40 mm frames aaYY-ZZ-xxx where "aa" can be Q. or B.; "YY" can be PLUS, PRO, PEAK, LINE PRO, LINE PLUS, PLUS DUO, PEAK DUO or TRON; and "ZZ" can be G3, G3.1, G4, G4.1, L-G2, L-G2.3, L-G3, L-G3.1, L-G3y, L-G4, L-G4.2, L-G4y, LG4.2/TAA, BFR-G3, BLK-G3, BFR-G3.1, BLK-G3.1, BFR-G4, BFR-G4.1, BFR G4.3, BLK-G4.1, G4/SC, G4.1/SC, G4.1/TAA, G4.1/MAX, BFR G4.1/TAA, BFR G4.1/MAX, BLK G4.1/TAA, BLK G4.1/SC, EC-G4.4, G5, G5/SC, G5/TS, BLK-G5, BLK-G5/SC, BLK-G5/TS, L-G5, L-G5.1, L-G5.2, L-G5.2/H, L-G5.3, G6, G6/SC, G6/TS, G6+/TS, G6+, BLK-G6, L-G6, L-G6.1, L-G6.2, L-G6.3, L-G6.3/BFG, G7, BLK-G6+, BLK-G6+/AC, BLK-G6+/HL, BLK-G6+/SC, BLK-G6/TS, BLK-G6+/TS, BLK-G7, G7.2, G8, BLK-G8, G8+, BLK-G8+ L-G7, L-G7.1, L-G7.2, L-G7.3, L-G8, L-G8.1, L-G8.2, L-G8.3, L-G8.3/BFF, L-G8.3/BFG, L-G8.3/BGT, M-G2+, BLK M-G2+, BLK M-G2.H+, BLK M-G2+/AC, BLK M-G2.H1+/AC, ML-G9, BLK ML-G9, ML-G9+, BLK ML-G9+, BLK-G10, BLK-G10+, BLK G10+/AC, BLK-G10+/HL, ML-G10, BLK ML-G10, ML-G10+, BLK ML-G10+, ML-G10.a, BLK ML-G10.a, ML-G10.a+, BLK ML-G10.a+, BLK ML-G10.B+, BLK ML-G10.C+, BLK ML-G10 +/t, BLK ML-G10+/TS, XL-G2.3/BFG, XL-G9, XL-G9.2, XL-G9.3, XL-G9.3/BFG, XL-G10.2, XL-G10.3, XL-G10.c, XL-G10.d, XL-G10.d/BFG, XL-G10.3/BFG, XL-G11.2, XL-G11.3, XL-G11.3/BFG or XL-G11S.3/BFG</p>
Rayzon Solar	<p>Rayzon Solar modules with 35 and 40 mm frames RSYxxxWC Where "Y" can be blank or B</p>
Recom	<p>Recom modules with 35 and 40 mm frames RCM-xxx-6yy Where "yy" can be MA, MB, ME or MF</p>
REC Solar	<p>REC modules with 30 and 38 mm frames RECxxxYYZZ Where "YY" can be AA, M, NP, NP2, NP3, PE, PE72, TP, TP2, TP2M, TP2SM, TP2S, TP3M or TP4; and "ZZ" can be blank, Black, BLK, BLK2, SLV, 72, Pro M, Pure, Pure-R, Pure-RX or Pure 2</p>
Renesola	<p>ReneSola modules with 35 and 40 mm frames AAxxxY-ZZ Where "AA" can be SPM(SLP) or JC; "Y" can be blank, F, M or S; and "ZZ" can be blank, Ab, Ab-b, Abh, Abh-b, Abv, Abv-b, Bb, Bb-b, Bbh, Bbh-b, Bbv, Bbv-b, Db, Db-b, or 24/Bb</p>
Renogy	<p>Renogy Modules with 35 and 40 mm frames RZZ-xxxY-AAA Where "ZZ" can be NG or SP; "Y" can be D or P; and "AAA" can be blank, 144, BB-108, BB-120 or BK-120</p>
Risen	<p>Risen Modules with 30, 35 and 40 mm frames RSMyy-a-xxxZZ Where "yy" can be 60, 72, 110, 120, 132 or 144; "a" can be 6, 7 or 8; and "ZZ" can be M, P or BMDG</p>
Saatvik	<p>Saatvik Modules with 35 mm frames SGExxx-YYYYZZ Where "YYYY" can be 108 or 144; and "ZZZ" can be MHC, MBHC or MHCB</p>
S-Energy	<p>S-Energy modules with 35 and 40 mm frames SABB-CCYYY-xxxZ Where "A" can be C, D, L or N; "BB" can be blank, 20, 25, 40 or 45; "CC" can be blank, 60 or 72; "YYY" can be blank, BDE, MAE, MAI, MBE, MBI, MCE or MCI; and "Z" can be V, M-10, P-10 or P-15</p>
SEG Solar	<p>SEG Solar with 30, 35 and 40 mm frames SEG-aYY-xxx-ZZ Where "a" can be blank, 6 or B; "YY" can be blank, MA, MB, PA, or PB; and "ZZ" can be blank, BB, BG, BW, HV, WB, WW, BMB, BMA-HV, BMA-BG, BMA-TB, BMB-TB, BMB-HV, BMD-BG, BMD-HV, BMB-BG, BTA-BG, BTB-BG, BTC-BG, BTD-BG or BMD-TB</p>
Seraphim USA	<p>Seraphim modules with 30, 35 and 40 mm frames SRP-xxx-YYY-ZZ Where "xxx" is the module power rating; and "YYY" can be BMA, BMD, 6MA, 6MB, 6PA, 6PB, 6QA-XX-XX, and 6QB-XX-XX; ZZ is blank, BB, BG or HV</p>
Sharp	<p>Sharp modules with 35 and 40 mm frames NUYYxxx Where "YY" can be SA or SC</p>

## MODULE COMPATIBILITY

Shinsung E&G	Shinsung Modules with 35 mm frames SSVxxx-144MH
Silfab	Silfab Modules with 35 and 38 mm frames SYY-Z-xxxAb Where "YY" can be IL, SA, LA, SG or LG; "Z" can be blank, M, P, or X; "A" can be blank, B, H, M, N, Q or X; and "b" can be A, C, C+, D, G, K, L, M, M+, N, T, U or X
Sinotec	Sinotec Modules with 30 and 35 mm frames STS-xxxP-aabb Where "aa" can be 54 or 72; and "bb" can be BB, DB or DD
Sirius PV	Sirius PV Modules with 35 mm frames ELNSMzzM-HC-yy-xxx Where "zz" can be 54 or 72; and "yy" can be blank or BF
Solar4America	Solar4America modules with 30, 35 and 40 mm frames S4Axxx-YYzzAA Where "YY" can be 60, 72, 108 or 144; "zz" can be MH5, MH10, TH10 or TH16; and "AA" can be blank or BB, BW, SW or STT
Solarever	Solarever modules with 30, 35 mm frames SE-zzz*yy-xxxM-aaa Where "zzz" can be 166 or 182; "yy" can be 83, 91 or 105; and "aaa" can be 108, 96-BD, 120-BH, 144 or 144N
Solaria	Solaria modules with 35 and 40 mm frames PowerA-xxxY-ZZ Where "A" can be X or XT, "Y" can be R or C; and "ZZ" can be blank, AC, BD, BX, BY, PD, PL, PM, PM-AC, PX, PZ, WX, WZ or 4T
Solarcity (Tesla)	Solarcity modules with 40 mm frames SCxxxYY Where "YY" can be blank, B1 or B2
SolarSpace	SolarSpace modules with 30 and 35mm frames SS8-yyzzz-xxxA Where "yy" can be 54 or 72; "zzz" can be HD, HDB or HSB; and "A" can be M or N
SolarTech	SolarTech modules with 40 mm frames AAA-xxxYY Where "AAA" can be PERCB-B, PERCB-W, HJT B-B, HJT B-W or STU; "YY" can be blank, PERC or HJT
SolarWorld AG	SolarWorld Sunmodule Plus, Protect, Bisun, XL, Bisun XL, may be followed by mono, poly, duo, black, bk, or clear; modules with 31 and 33 mm frames SW-xxx
SolarWorld Americas	SolarWorld Sunmodule Plus, Protect, Bisun, XL, Bisun XL, may be followed by mono, poly, duo, black, bk, or clear; modules with 33 mm frames SWA-xxx
Sonali	Sonali Modules with 35 and 40 mm frames SS-M-xxx-yyy Where "M" can be blank or M; and "yyy" can be blank or 108M-B
Star Solar	Star Solar modules with 35 mm frames Star-xxxW-YYY-ZZZ Where "YYY" can be M60H or M60HB; and "ZZZ" can be blank or M10
Stion	Stion Thin film modules with 35 mm frames STO-xxx or STO-xxxA
SunEdison	SunEdison Modules with 35 and 40 mm frames SE-YxxxZABCDE Where "Y" can be B, F, H, P, R, or Z; "Z" can be 0 or 4; "A" can be B,C,D,E,H,I,J,K,L,M, or N; "B" can be B or W; "C" can be A or C; "D" can be 3, 7, 8, or 9; and "E" can be 0, 1 or 2
Sungold	Sungold Modules with 35 mm frames SG-xxxWM

## MODULE COMPATIBILITY

Suniva	Suniva modules with 35, 38 and 40 mm frames OPTxxx-AA-B-YYY-Z MVXxxx-AA-B-YYY-Z Where "AA" is either 60 or 72; "B" is either 4 or 5; "YYY" is either 100,101,700,1B0, or 1B1; and "Z" is blank or B
Sunket	Sunket modules with 35 mm frames SKTxxxM10-144S1
Sunmac Solar	Sunmac modules with 30 and 35 mm frames SMxxxMaaaZZ-YY Where "aaa" can be 660, 754 or 772; "ZZ" can be NH or SH; and "YY" can be BB or TB
Sunpower	Sunpower standard (G3 or G4) or InvisiMount (G5) 35, 40 and 46 mm frames SPR-Zb-xxx-YY Where "Z" can be A, E, M, P or X; "b" can be blank, 17, 18, 19, 20, 21, or 22; and "YY" can be blank, BLK, COM, C-AC, D-AC, E-AC, BLK-E-AC, G-AC, BLK-G-AC, H-AC, BLK-H-AC, BLK-C-AC, or BLK-D-AC
Sunspark	Sunspark modules with 40 mm frames SYY-xxxZ-A Where "YY" can be MX or ST; and "Z" can be M, MB, M3, M3B, P or W; and "A" can be 60 or 72
Suntech	Suntech modules with 35 and 40 mm frames STPxxx-y-zz/aa Where "y" is blank or S; and "zz" can be 20, 24, A60, A72U, B60 or B72; and "aa" can be Vd, Vem, Vfw, Vfh, Vnh, Wdb, Wde, Wd, Wfhh or Wnhb
Talesun	Talesun modules with 30, 35 and 40 mm frames TAByZZaa-xxx-b Where "A" can be D, M or P; "B" can be 3, 6, 7 or 9; "y" can be blank, F, G, H, I or L; "ZZ" can be 48, 54, 60, 66, 72 or 78; "aa" can be M, M(H), or P; and "b" can be blank, B, T, or (H)
Tata Power Renewable Energy	TP Solar Ltd modules with 30mm frames TPxxxHG10B
Tesla	Tesla modules with 40 mm frames TxxxY Where "Y" can be H or S
Thornova	Thornova Modules with 30 and 35 mm frames TS-YYZZ(xxx)-X Where "YY" can be BB, BBT, BG or BGT; "ZZ" can be 54, 60 or 72; and "X" can be blank, G11 or X
Trina	Trina Modules with 30, 35 and 40 mm frames TSM-xxxYYZZ Where "YY" can be DD05, DD06, DD14, DE14, DE15, DE15V, DEG15, DEG15VC, DE18M, DEG18MC, DE09, DE19, DEG19C.20, DE06X, PA05, PC05, PD05, PD06, PA14, PC14, PD14, PE14, PE15, NE19RC, NEG19RC, NE09RC or NE09RH.05 ; and "ZZ" can be blank, .05, .05(II), .08, .08(II), .10, .18, .08D, .18D, 0.82, .002, .00S, 05S, 08S, .20, .20(II), A, A.05, A.08, A.10, A.18, (II), A(II), A.05(II), A.08(II), A.082(II), A.10(II), A.18(II), C.05, C.07, C.05(II), C.07(II), H, H(II), H.05(II), H.08(II), HC.20(II), HC.20(II), M, M(II), M.05(II), MC.20(II)
Universal	Universal Solar modules with 35 mm frames UNI-xxx-yyyZZZ-aa Where "yyy" can be 108, 120 or 144; "ZZZ" can be M, MH, BMH; and "aa" can be blank, BB or DG
URE	URE modules with 35 mm frames DyZxxxxaa Where "D" can be D or F, "y" can be A, B, 6 or 7; "Z" can be F, K, L or M; and "aa" can be B8G, BFG, BFG-BB, C8G, DFG-BB, H3A, H4A, H8A, L4A, E7G-BB, E8G, E8G-BB, MFG, MFG-BB or M7G-BB
Vikram	Vikram solar modules with 30, 35 and 40 mm frames XVSyy.ZZ.AAA.bb Where "X" can be blank, Hypersol, Paradea, Prexos or Somera; "yy" can be M, P, MBB, MDH, MDHT, MH, MS, MHBB, or PBB; "ZZ" can be 54, 60, 72 or 78; "AAA" is the module power rating; and "bb" can be 03, 04 or 05
VSUN	VSUN modules with 30, 35 and 40 mm frames VSUNxxxA-YYz-aa Where "A" can be blank or N; "YY" can be 60, 72, 108, 120, 132, 144; "z" can be M, P, MH, PH, or BMH; and "aa" can be blank, BB, BW, or DG

## MODULE COMPATIBILITY

Waaree	<p>Waaree modules with 35 and 40 mm frames                      AAyy-xxx                      Where "AA" can be WS or Bi; and "yy" can be blank, M, MB, MD, MDI, MDIB, 33, 55, 57 or 66</p>
Winaico	<p>Winaico modules with 35 and 40 mm frames                      Wsy-xxxZa                      Where "y" can be either P or T; "Z" can be either M, P, or MX; and "a" can be blank or 6</p>
Yingli	<p>Yingli modules with 30, 35 and 40 mm frames                      YLxxxZ-yy                      Where "Z" can be D or P; "yy" can be blank, 29b, 30b, 34d, 35b, 36b, 37e 1/2, 37e 1500V 1/2, 40d, 49e 1/2 or 49e 1500V 1/2</p>
Yotta	<p>Yotta modules with 30 and 35 mm frames                      YSM-Bxxx-ZZ-72-1                      Where "ZZ" can be 06 or 10</p>
Zeus	<p>Zeus Solar Modules with 40 mm frames                      ZxxxM-HB</p>
ZN Shine	<p>ZN Shine modules with 30 and 35 mm frames                      ZXMY-AAA-xxx/M                      Where "Y" can be 6, 7 or 8; "AAA" can be 72, NH120, NH144, NHDB144, NHLDD144, SH108, SH144, SHDB120, SHDB144, SHLDD144, TP120, TPLDD120 or UHLDD144; and "M" can be M or N</p>

## MODULE COMPATIBILITY

Module Clamping provided by others

### FRAMELESS MODULE LIST

MAKE	MODELS
Astronergy Solar	Astronergy frameless modules CHSM6610P(DG)-xxx
Canadian Solar	Canadian Solar frameless modules CSbY-xxx-Z Where "b" can be 3 or 6; "Y" is K, P, U, or X; and "Z" can be M-FG, MS-FG, P-FG, MB-FG, or PB-FG
Heliene	Heliene frameless modules YYZZxxxA Where "YY" can be 72; "ZZ" can be M; and "A" can be GH
Jinko	Jinko frameless modules JKMxxxPP-DV
Prism Solar	Prism Solar frameless modules BZYY-xxxAAA Where "Z" can be i or N; "YY" can be 48, 60, 60S, 72 or 72S; and "AAA" can be blank or BSTC
Risen	Risen frameless modules RSMyy-6-xxxZZ Where "yy" can be 60, 72, 120 or 144; and "ZZ" can be MDG or PDG
Stion	Stion frameless modules STL-xxx or STL-xxxA
Sunpreme	Sunpreme frameless modules GXB-xxxYY Where "YY" can be blank or SL
Trina	Trina frameless modules TSM-xxxYY Where "YY" can be either DEG5(II), DEG5.07(II), DEG5.40(II), DEG5.47(II), DEG14(II), DEG14C(II), DE- G14C.07(II), DEG14.40(II), PEG5, PEG5.07, PEG5.40, PEG5.47, PEG14, or PEG14.40