



User Manual

Xcellent Plus-US

A04 VERSION



E-mail: support@renonpower.com

Website: www.renonpower.com

Renon Power Technology Inc.

© Renon Power Technology Inc.
All Rights Reserved Specifications are subject to change without notice.



Renon Power

We Care About Sustainability

With our own R&D team and automated production factory, we are dedicated to delivering innovative, reliable, and affordable energy storage solutions to customers globally.

At Renon, we believe that sustainable energy is the future. We are passionate about reducing carbon emissions and preserving our planet for future generations. That's why we invest heavily in research and development, leveraging the latest technologies to design and manufacture energy storage systems that are efficient, scalable, and adaptable.

Our products are designed to meet the needs of a wide range of applications, from residential and commercial buildings to industrial facilities and utility-scale projects. Whether you're looking to reduce your energy bills, increase your energy independence, or support your sustainability goals, Renon has the right solution for you.

Our commitment to quality and customer satisfaction is unwavering. We work closely with our clients to understand their unique needs and provide customized solutions that meet or exceed their expectations. We also provide comprehensive technical support, maintenance, and warranty services to ensure that our customers get the most out of their investment.

[JOIN US ON OUR MISSION TO MAKE RENEWABLE ENERGY WITHIN REACH.](#)

**PROVIDE INNOVATIVE,
RELIABLE, AND
AFFORDABLE ENERGY
STORAGE SOLUTIONS
TO CUSTOMERS**



Table of Contents

1 Safety Instructions	6
1.1 General Safety Precautions	6
1.2 Transportation and Storage Precautions	6
1.3 Installation Precautions	7
1.4 Usage Precautions	8
1.5 Response to Emergency Situations	8
1.6 Qualified Personnel	9
2 Preparation Before Installation	10
2.1 Safe Handling Guide	10
2.1.1 Familiarize Yourself with the Battery	10
2.1.2 Precautions	10
2.1.3 Tools	10
2.1.4 Safety Gear	11
2.2 System Premeasurement	11
2.3 Installation Location	12
2.4 Package Items	13
3 Installation	15
3.1 Device Installation	15
3.2 Connection	20
3.3 Power On	21
3.4 Application Scenarios	22
3.4.1 Two Batteries	23
3.4.2 Multiple Parallel	23
4 Cloud Platform Configuration	24
5 Battery Specifications	32
5.1 Product Features	32
5.2 Specifications	33
5.3 External Introduction	34
5.3.1 Explosion-proof Valves	34

5.3.2 Power Button	34
5.3.3 LED	34
5.4 Function Introduction	36
5.4.1 Protection	36
5.4.2 Heating	36
5.4.3 Forced Discharge	36
5.4.4 Full Charge	36
5.4.5 Charging Self-Adaptation Control	36
5.4.6 Safety Lock	36
5.5 Interface Information	37
5.5.1 LINK IN Parallel Communication Port	38
5.5.2 INV COM Port	38
5.5.3 LINK OUT Parallel Communication Port	39
5.5.4 Inverter Communication Port	39
5.5.5 Debug Port	40
5.5.6 Inverter Dial Switch	40
5.5.7 Function Dial Switch	41
5.5.8 Address Dial Switch	42
5.5.9 Dry Contact	44
5.5.10 INV Communication Port	44
5.5.11 Power Positive & Negative	45
5.5.12 Dial Code Switch	45
5.5.13 Emergency Stop	47
6 Troubleshooting & Maintenance	48
6.1 Regular Maintenance	48
6.2 Troubleshooting	48
6.3 Status Code	49
6.3.1 Warning Codes	49
6.3.2 Error Codes	51

6.3.3 Protection Codes 53

1 Safety Instructions

For safety reasons, installer and user are responsible for familiarizing themselves with the contents of this document and all warnings before installation and usage.

1.1 General Safety Precautions

- Please carefully read this manual before any work is carried out on the product, and keep it located near the product for future reference.
- All installation and operation must comply with local electrical standards.
- Please ensure the electrical parameters of the product are compatible to related equipment.
- Do not open or dismantle the battery module. Electrolyte is very corrosive. In normal working conditions contact with the electrolyte is impossible. If the battery casing is damaged, do not touch the exposed electrolyte or powder because it is corrosive.
- The electronics inside the product are vulnerable to electrostatic discharge.
- Do not place items or tools on the product.
- Do not damage the product by dropping, deforming, impacting, or cutting.
- Keep the product away from liquid. Do not touch the product if liquid spills on it. There is a risk of electric shock.
- Do not expose the product to flammable or harsh chemicals or vapors.
- Do not paint any part of the product, include any internal or external components.
- Do not change any part of the product, especially the battery and cell.
- Besides connection under this manual, any other foreign object is prohibited from being inserted into any part of the product.
- The warranty claims are excluded for direct or indirect damage due to items above.
- Batteries must not be mixed with domestic or industrial waste.
- Batteries marked with the recycling symbol must be processed via a recognized recycling agency. By agreement, they may be returned to the manufacturer.

1.2 Transportation and Storage Precautions

- The batteries must be transported according to UN3480, they must be packed according to packaging requirements of Special Regulation 230 of IMDG CODE (40-20 Edition) for maritime transport, and P965 IA for air transport (SOC less than 30%). The original packaging complies with these instructions.

- If the product needs to be moved or repaired, the power must be cut off and completely shut down.
- The product must be transported in its original or equivalent package;
- The modules are heavy. Ensure adequate and secure mounting and always use suitable handling equipment for transportation.
- If the product is in its package, use soft slings to avoid damage.
- Do not stand below the product when it is hoisted.
- During transportation, severe impact, extrusion, direct sunlight, and rain should be avoided.
- Store in a cool and dry place.
- Store the product in clean environment, free of dust, dirt and debris.
- Store the product out of reach of children and animals.
- Don't store the battery under 50% SOC for over one month. This may result in permanent damage to the battery and void the warranty.
- During long term storage, it is required to charge the battery module every 3 months, and the SOC should be no less than 90%.

1.3 Installation Precautions

- Do not install the product in an airtight enclosure or in an area without ventilation.
- Do not install the product in living areas of dwelling units or in sleeping units other than within utility closets and storage or utility spaces.
- If the product is installed in a garage or carport, ensure there is adequate clearance from vehicles.
- While working on the product wear protective eyeglasses and clothing.
- Handle the battery wearing insulated gloves.
- Use insulated tools. Do not wear any metallic items such as watches, bracelets, etc.
- Turn-off related circuit breakers before and during the installation to avoid electric shock.
- Do not connect any AC conductors or photovoltaic conductors directly to the battery pack. These are only to be connected to the inverter.
- Wiring must be correct, do not mistake the positive and negative cables, and ensure no short circuit with the external device.
- Over-voltages or wrong wiring could damage the battery pack and cause combustion which can be extremely dangerous.
- Make sure the product is well grounded, and complies with local specifications. The recommended grounding resistance is less than 1Ω .

- Handle with care because Li-ion Battery is sensitive to mechanical shock.

1.4 Usage Precautions

- Before starting the system, the operator should strictly check the connection terminals to ensure that the terminals are firmly connected.
- If there's a circuit breaker between battery and inverter, the breaker is supposed to be on before powering on the battery.
- Do not open the product, connect, or disconnect any wires when it's working to avoid electric shock.
- Battery needs to be recharged within 12 hours after fully discharging.
- The default temperature range over which the battery can be discharged is -4°F (-20°C) to 122°F (50°C). Frequently discharging the battery in high or low temperature may deteriorate the performance and life of the battery pack.
- The default temperature range over which the battery can be charged is 32°F (0°C) to 122°F (50°C). Frequently charging the battery in high or low temperature may deteriorate the performance and life of the battery pack.
- Do not charge or discharge a damaged battery.
- Please contact the supplier within 24 hours if there is something abnormal.

1.5 Response to Emergency Situations

- Damaged batteries are dangerous and must be handled with extreme care. They are not suitable for use and may cause danger to people or property. If the battery pack appears to be damaged, place it in the original container and return it to an authorized dealer.
- If the battery pack is wet or submerged in water, do not allow anyone to touch the water, and then contact authorized dealer for technical support.
- In case of fire, use carbon dioxide, FM-200 or ABC dry powder fire extinguisher; if possible, move the battery pack to a safe area before it catches fire.
- If a user happens to be exposed to the internal materials of the battery cell due to damage on the outer casing, the following actions are recommended.
- In case of inhalation: Leave the contaminated area immediately and seek medical attention.
- In case of contact with eyes: Rinse eyes with running water for 15 minutes and seek medical attention.
- In case of contact with skin: Wash the contacted area with soap thoroughly and seek medical attention.

- In case of ingestion: Induce vomiting and seek medical attention.

1.6 Qualified Personnel

The installation guide part described herein is intended for use by skilled staff only. Skilled staff is defined as a trained and qualified electrician or installer who has all the following skills and experience:

- Knowledge of battery specification and properties.
- Knowledge of the installation of electrical devices.
- Knowledge of torsion and screwdrivers for different types of screws.
- Knowledge of local installation standards.
- Electrical license for battery installation required by the country or state.
- Knowledge of the dangers and risks associated with installing and using electrical devices and acceptable mitigation methods.
- Knowledge of and adherence to this guide and all safety precautions and best practices.
- For safety reasons, installers are responsible for familiarizing themselves with the contents of this document and all warnings before performing installation and usage.

2 Preparation Before Installation

2.1 Safe Handling Guide

2.1.1 Familiarize Yourself with the Battery

Be careful when unpacking the system. Every module of the product is heavy. Don't lift them with a pole. The weight of the modules can be found in the chapter "**Specifications**".

Familiarize yourself with the battery. The battery poles are located on the top and bottom sides of the battery module. It's designed of fast mounting and simplicity. No need to recognize the positive and negative poles, but take care of them especially the bottom one.

2.1.2 Precautions

Before installation, be sure to read the contents in chapter "**Safety Precautions**", which is related to the operation safety of installation personnel, please pay attention to it.

2.1.3 Tools

The following tools are required to install the product:



Cordless Drill

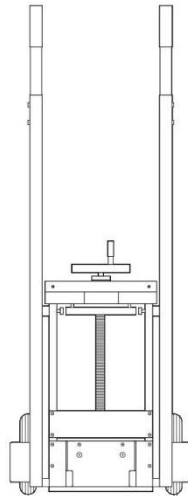

Dolly

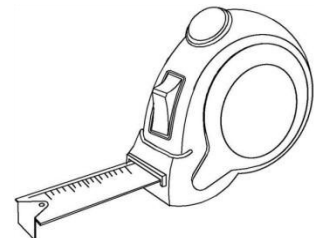

Measuring Tape

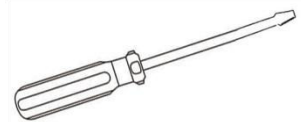

Flathead Screwdriver

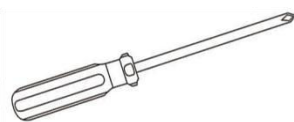

Phillips Screwdriver

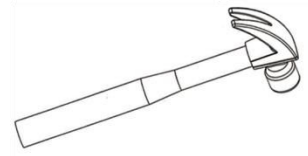

Hammer

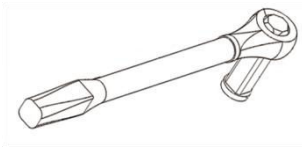

Torque Wrench

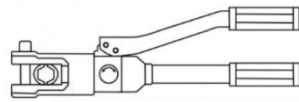

Hydraulic Clamp

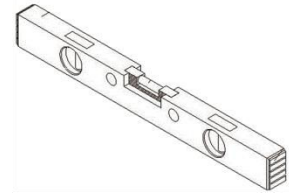

Spirit Level

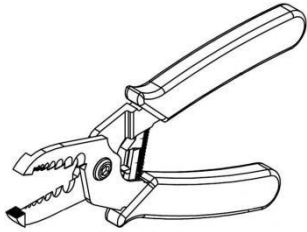

Crimping Pliers

Use properly insulated tools to prevent accidental electric shock or short circuits. If insulated tools are not available, cover all exposed metal surfaces of the available tools, except their tips, with electrical tape.

2.1.4 Safety Gear

It is recommended to wear the following safety gear when dealing with the product:



Insulated Gloves

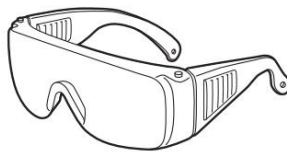

Safety Goggles



Safety Shoes

2.2 System Premeasurement

The battery requires adequate clearance for installation and airflow. The minimum clearance for system configuration is given below. The cable connected between battery pack and inverter should be in accordance with the installation guide or manual of the inverter.

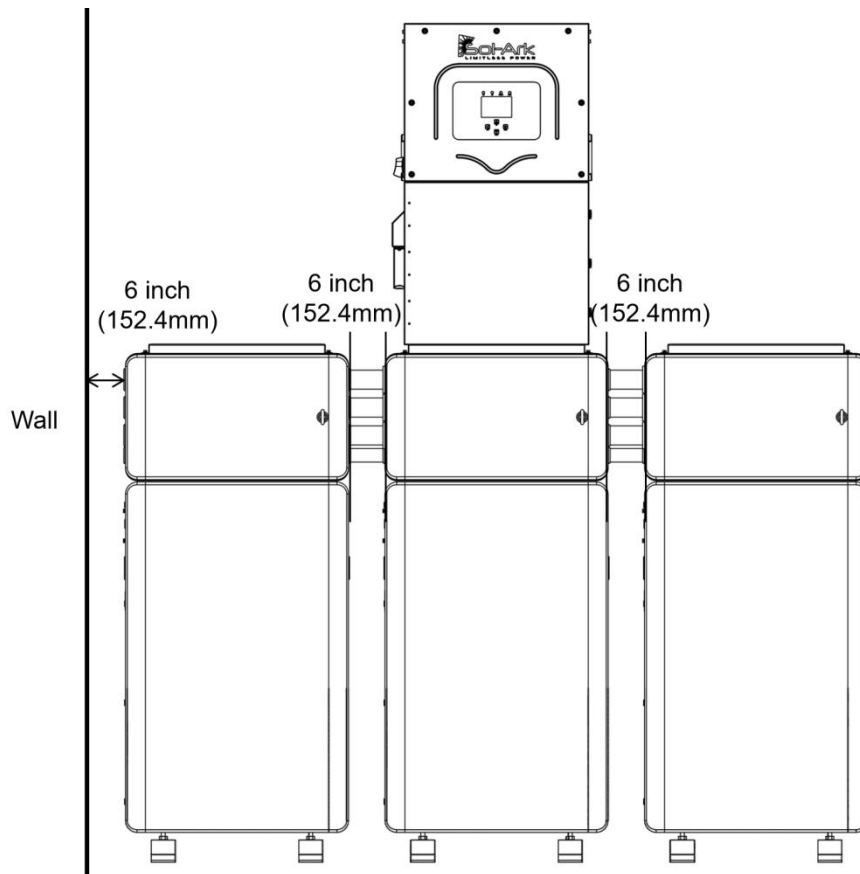

Figure 2.2.1. Installation distance

2.3 Installation Location











Make sure that the installation location meets the following conditions:





- The surface of the wall is smooth and perpendicular to the ground, which can bear the weight.
- The area is completely water proof. (Recommended)
- The area shall avoid direct sunlight. (Recommended)
- There are no flammable or explosive materials.
- The distance from heat source is more than 80 in (2m).
- The ambient temperature should not exceed the range of battery usage temperature.
- The humidity should not exceed the range of battery usage humidity.
- There is minimal dust and dirt in the area.
- Avoid installation in an area confined or with high salinity.
- Do not place in an area accessible to children or pets.

2.4 Package Items

After receiving the product, please unpack the boxes, and check product and packing list first. If product is damaged or lacks parts, please contact the local retailer.

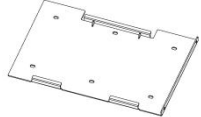
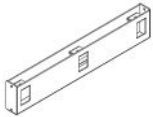
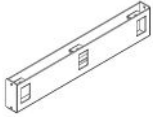
Xcellent Plus Packing List:

No.	Item	Specification	Qty	Usage	Diagram
1	Xcellent Plus	R-XC016161(-H)-US	1	Battery	
2	User manual	Xcellent Plus-US	1	User manual	
3	Embedded Screw	M6*16	7	Secure mounting panel on the wall	
4	Embedded Screw	M5*12	7	Secure holder to the battery	
5	Embedded Screw	M8*80	6	Secure holder to the battery	
6	Leveling Feet	∅ 60-M10-80	4	Support or use for adjusting height	
7	Connector	Connector plug, black	4	Use for wiring	
8	Connector	Connector plug, orange	4	Use for wiring	
9	Connector	RJ45	1	Use for wiring	
10	OT Terminal	RNB4-5	2	Use for wiring	

11	Mounting Panel	20*12.85*0.79in (508*326.4*20mm), T=3.0, SGCC	1	Mounting battery on the wall	
12	Holder 1	19.69*3.65*0.24in (500*92.7*39.6mm), T=3.0, SPCC, SGCC	1	Install onto the battery	
13	Holder 2	19.69*3.65*0.24in (500*92.7*39.6mm), T=3.0, SPCC, SGCC	1	Install onto the battery	
14	Communication Cable	RJ45, 35.43 in (900mm)	1	Parallel communication cable	
15	Communication Cable	RJ45, 27.56 in (700mm)	1	Battery communication cable to inverter	
16	Positioning Cardboard	3mm, 82.68x22.05 in (2100x560mm)	1	Use for locating the mounting hole positions.	
17	Quick Installation Manual	Xcellent Plus-US	1	Installation Manual	

3 Installation

3.1 Device Installation

Step 1:

- 1) Make sure the wall is sufficient to support the installation weight of the device. For product weight, check 5.2. Specifications for detail.
- 2) Pre-drill the holes in the wall according to the diagram, including the locations for the battery and inverter. Before drilling, use a spirit level to make sure the drilling template is perfectly horizontal.

Note:

- ① The mounting hole locations can be identified using the marking on the lower left positioning cardboard, with detailed positions shown in right side diagram.
- ② This positioning cardboard is designed for use with Sol-Ark 15K-2P-N inverter.

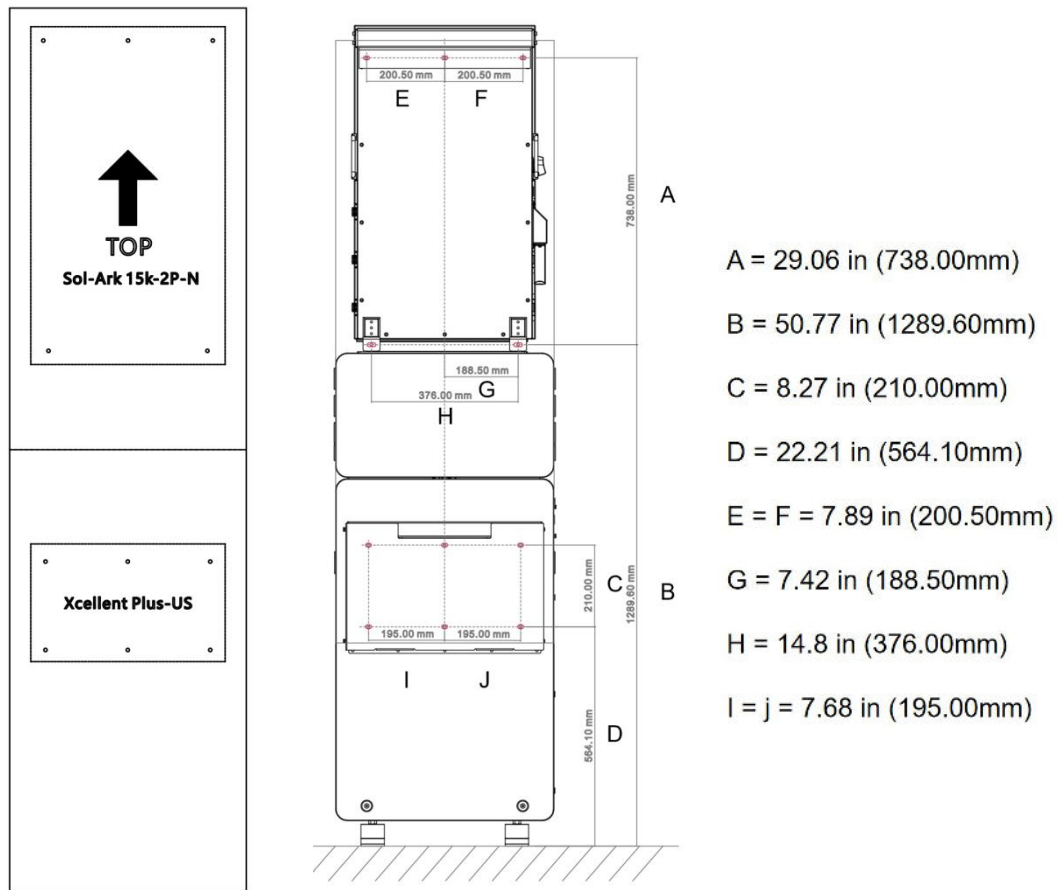

Figure 3.1.1. Positioning cardboard & Mounting hole position

- 3) Secure the mounting panel using 6*M8x80 expansion screws.

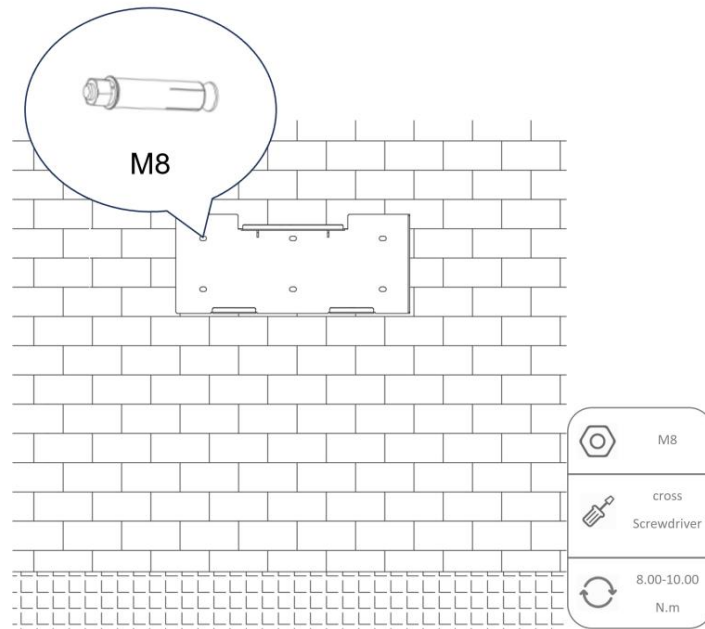

Figure 3.1.2. Mounting panel

4) Mounting leveling feet.

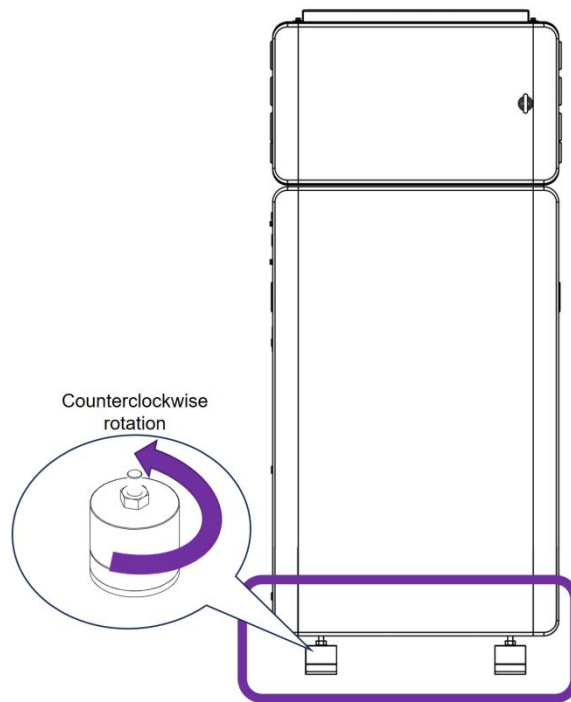

Figure 3.1.3. Leveling feet

5) Attach holder 1 and holder 2 using 6*M6x16 and 4*M5x12 screws.

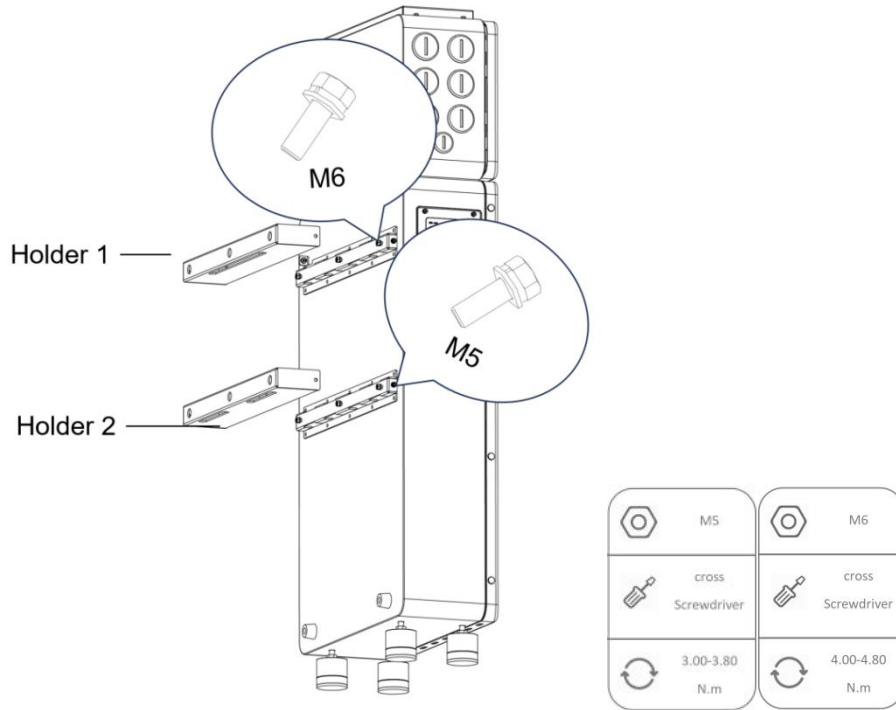

Figure 3.1.4. Holder installation

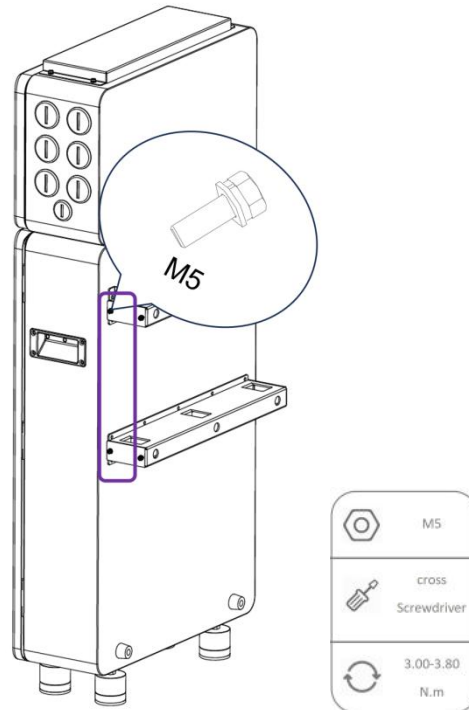

Figure 3.1.5. Left side screws

6) Mount the battery to the mounting panel using 2*M5x12 screws.

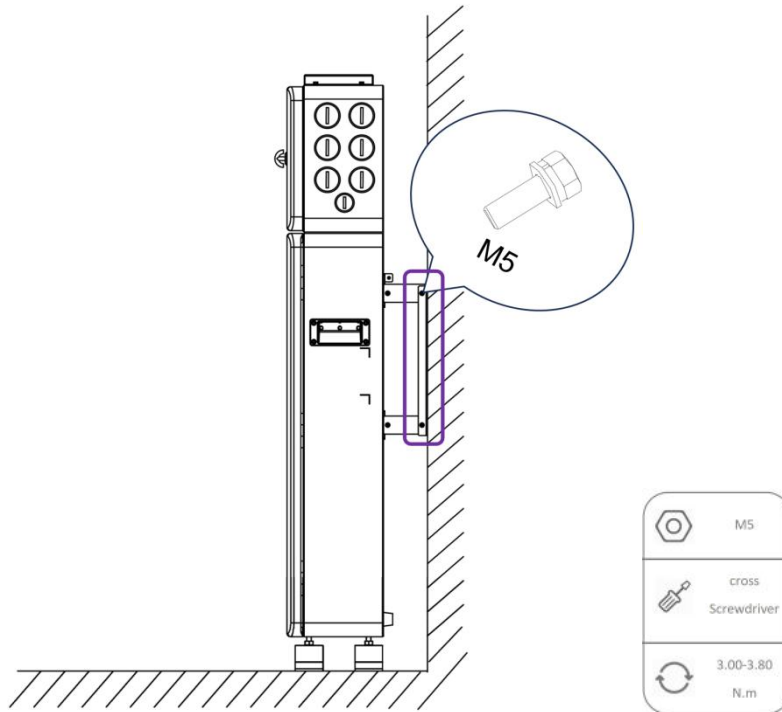

Figure 3.1.6. Install battery to the mounting panel

7) If slight misalignment is detected in the mounting holes after installation, a flush installation can be achieved by adjusting the leveling feet.

Note: The leveling feet can support the battery and be adjusted upward by 0.2 in (5mm).

Step 2:

1) Remove the cover of the junction box connected to the inverter above the battery.

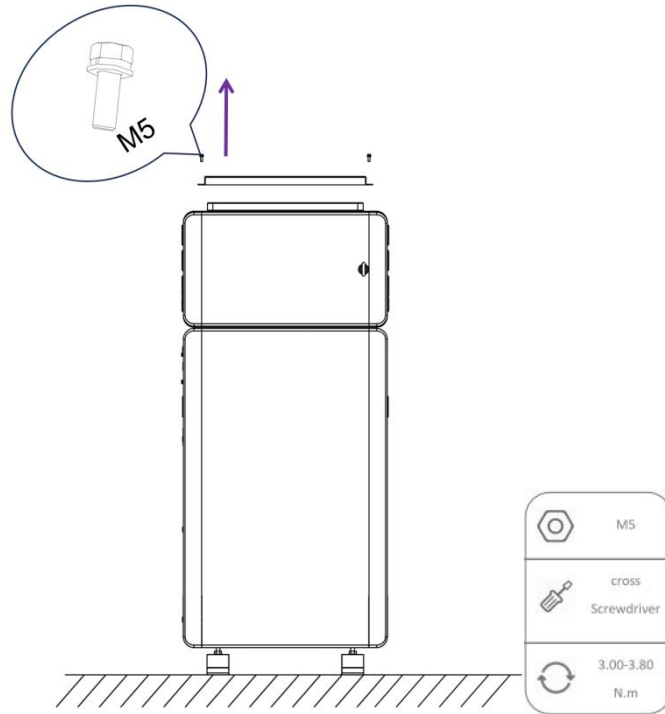

Figure 3.1.7. Remove cover of the junction box

Step 3:

1) Mount the inverter directly to the pre-drilled holes to ensure a secure installation.

Note: Refer to the Sol-Ark 15K-2P-N inverter installation guide.

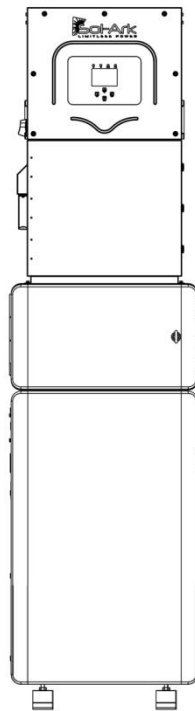





Figure 3.1.8. Battery

3.2 Connection

Cable Color Coding Specification:

 Positive power cable  Communication cable  Ground cable  Negative power cable

1. Unlock waterproof cover of junction box.

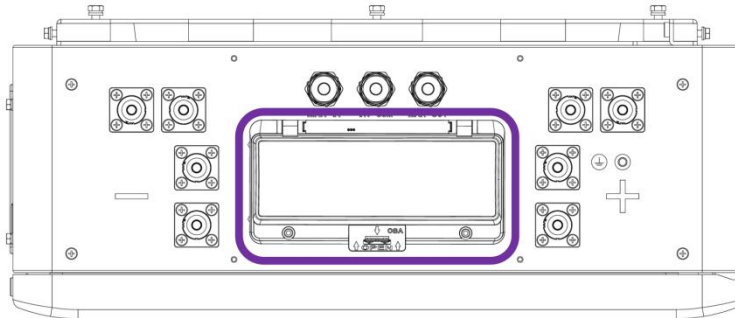

Figure 3.2.1. Unlock waterproof cover

2. Connect to inverter's power cable, communication cable and ground cable.

Power cable: 2/0 AWG

- 1) Connect the battery negative terminal to the inverter negative terminal.
- 2) Connect the battery positive terminal to the inverter positive terminal.
- 3) Connect the INV COM of battery to the BMS port of the inverter.
- 4) Connect the ground cable of battery to the inverter.

Note: This example uses Sol-Ark 15K-2P-N inverter for demonstration. For actual dial code settings, refer to the 5.5.5. Inverter Dial Switch.

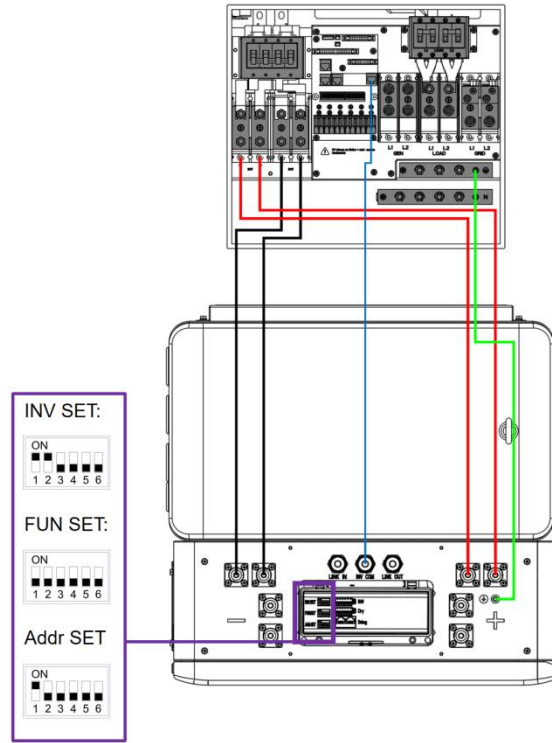

Figure 3.2.2. Single stack

3. If there is generator, load, or grid that needs to be connected, connect the inverter through the junction box to the corresponding external device directly.

4. Lock the waterproof cover of junction box and tighten the retention screws at both ends.

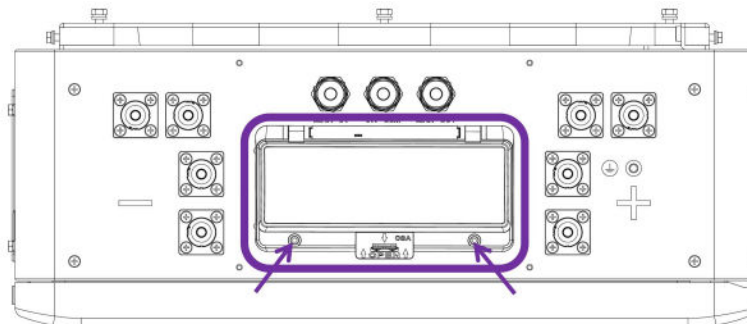

Figure 3.2.3. Lock waterproof cover of junction box

3.3 Power On

Note: To ensure proper power-up of the equipment, strictly follow the operating steps below.

Step 1: Turn on the DC switch of inverter.

The DC breaker position shown in the diagram is specific to Sol-Ark 15K-2P-N inverter. For other brands or models, refer to the respective product's user manual.

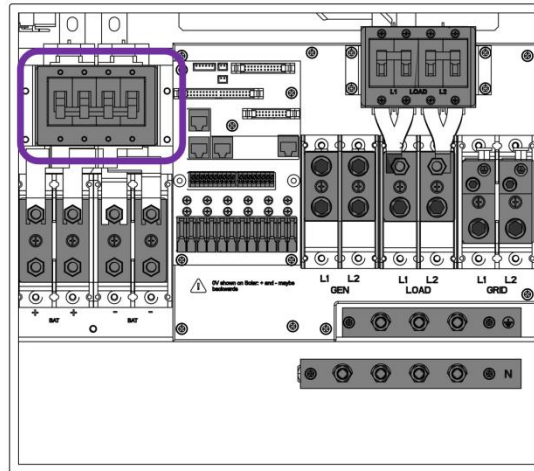

Figure 3.3.1. DC breaker

Step 2: Press the power button to use.

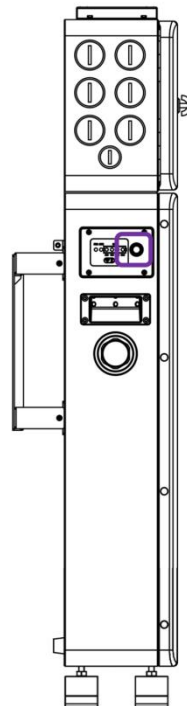

Figure 3.3.2. Power button

3.4 Application Scenarios

Note: If multiple battery units need to be connected in parallel, simply repeat the installation procedure described in Step 1 on both sides.

3.4.1 Two Batteries

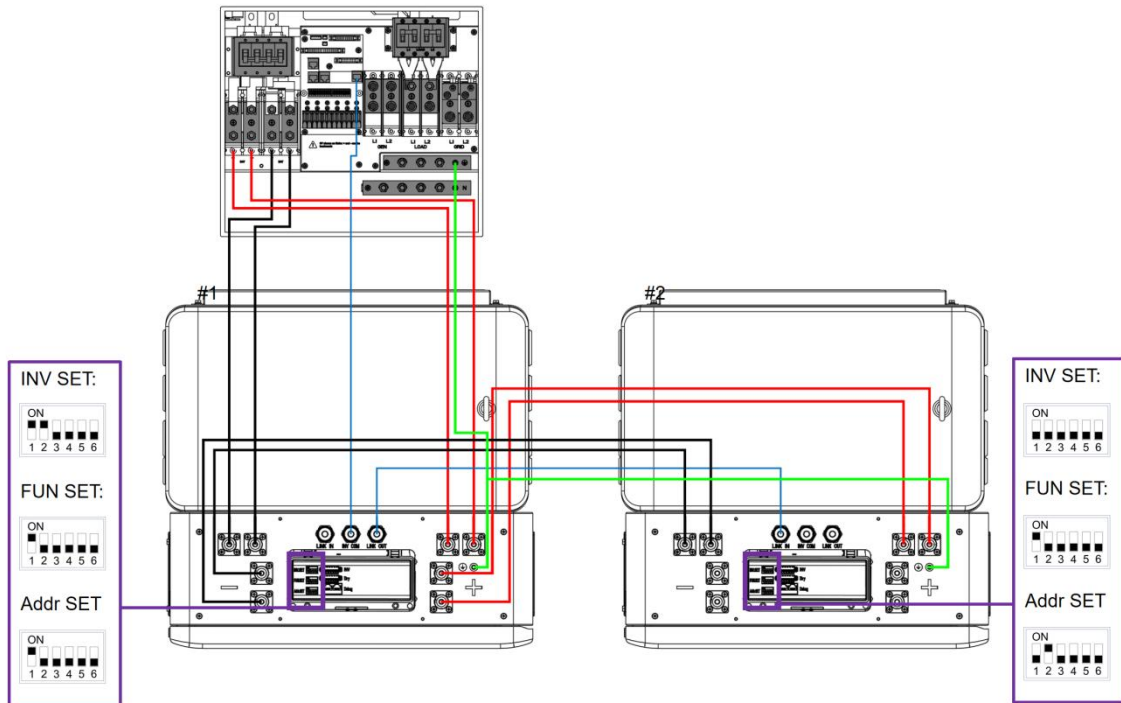

Figure 3.4.1. Two batteries in parallel connect with inverter

3.4.2 Multiple Parallel

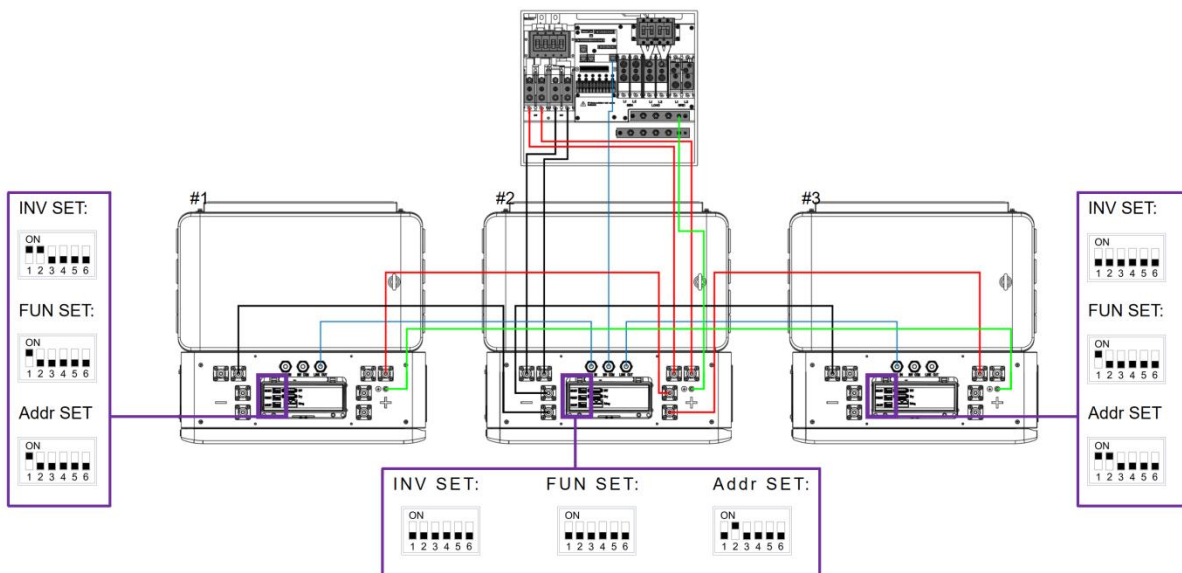

Figure 3.4.2. Multiple batteries in parallel connect with inverter

4 Cloud Platform Configuration

1) Download App

Download and install Renon app from Google play or App Store by searching “Renon Smart”.



Figure 4.1.1. Install Renon App



Figure 4.1.2. Android QR code



Figure 4.1.3. IOS QR code



2) Register

For new account registration, please retrieve the Registration Code from your installer. Existing users may log in directly, while new users must create an account.

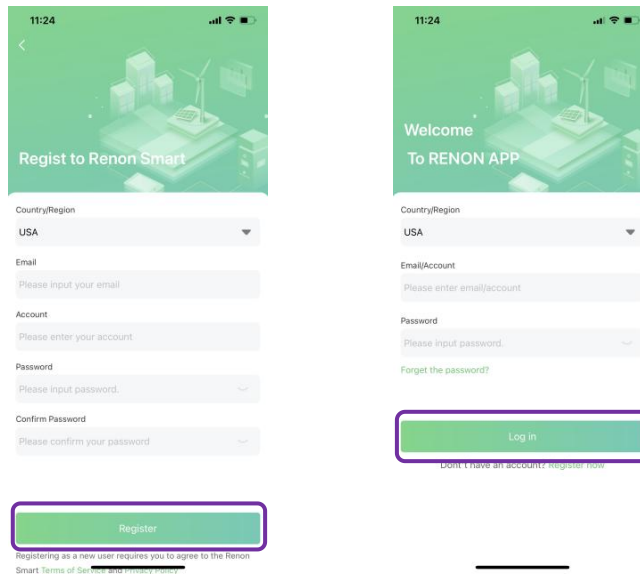

Figure 4.1.4. Register & Log in

3) Log in

This is a general user account.

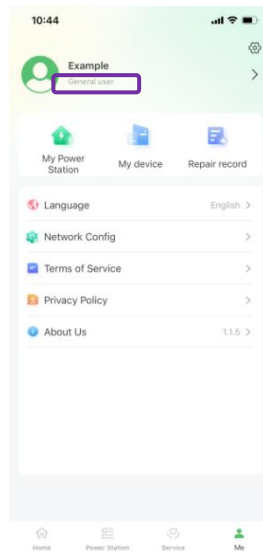

Figure 4.1.5. General user

4) Binding

Method 1:

a. Distribution

To register as an end user, scan the binding QR code provided by your installer, then request device assignment to your account.

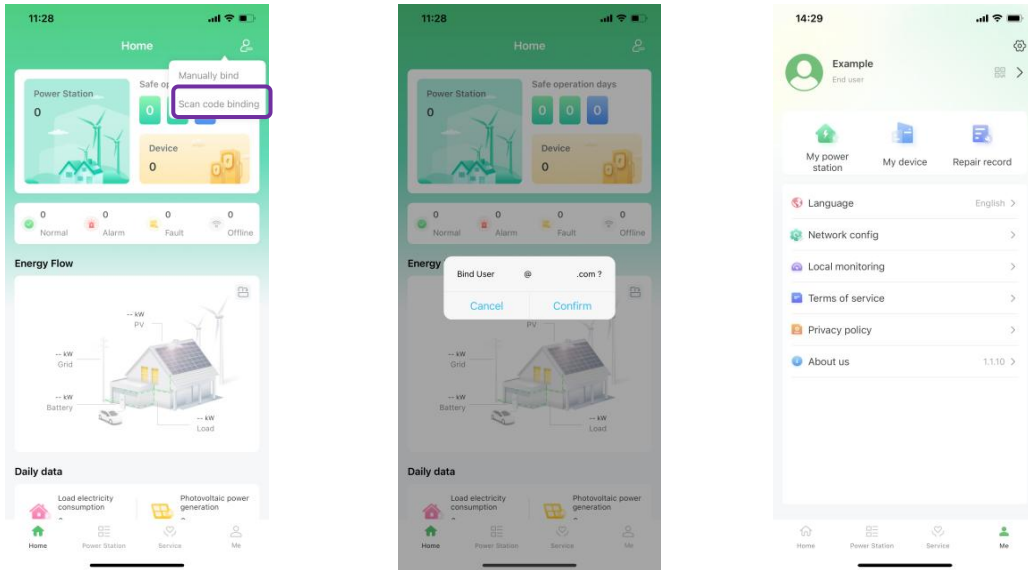

Figure 4.1.6. Scan upper-level account, Confirm binding & Become end user

b. Scan QR code

Select "Scan code binding" and scan the QR code using your device camera. Contact the installer if unsuccessful.

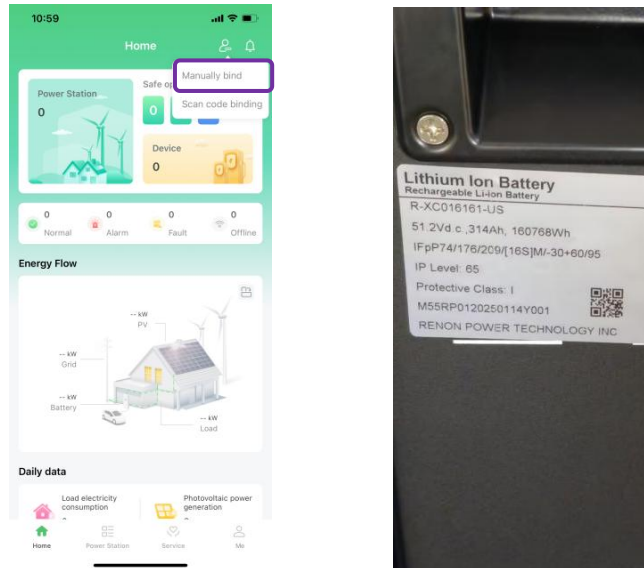

Figure 4.1.7. Scanning QR code

Method 2:

Click "My device" to enter the "Add a device" page, scan the QR code as illustrated, then select a upper-level account to complete binding.

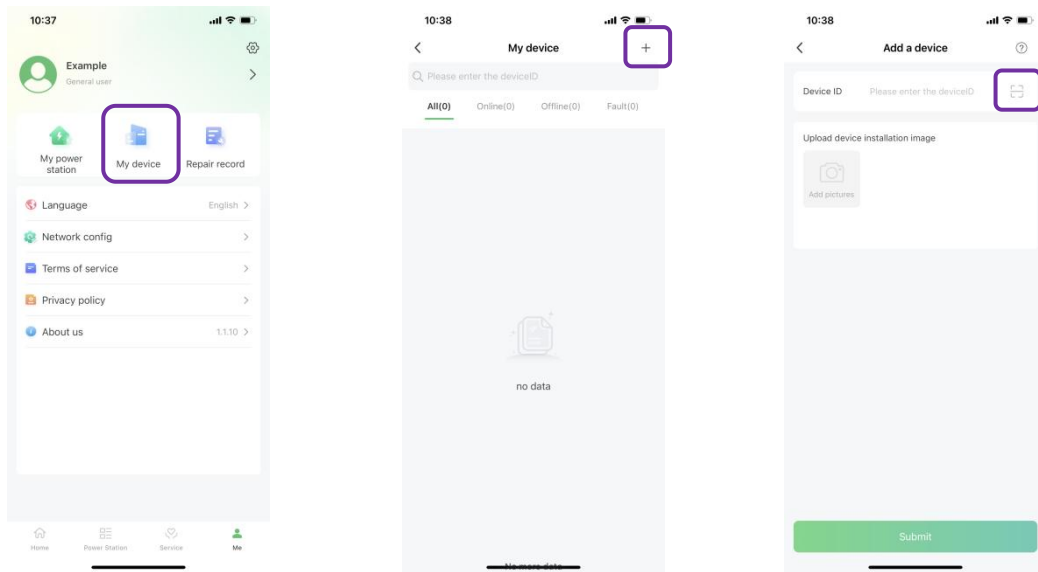

Figure 4.1.8. My device, add & scanning

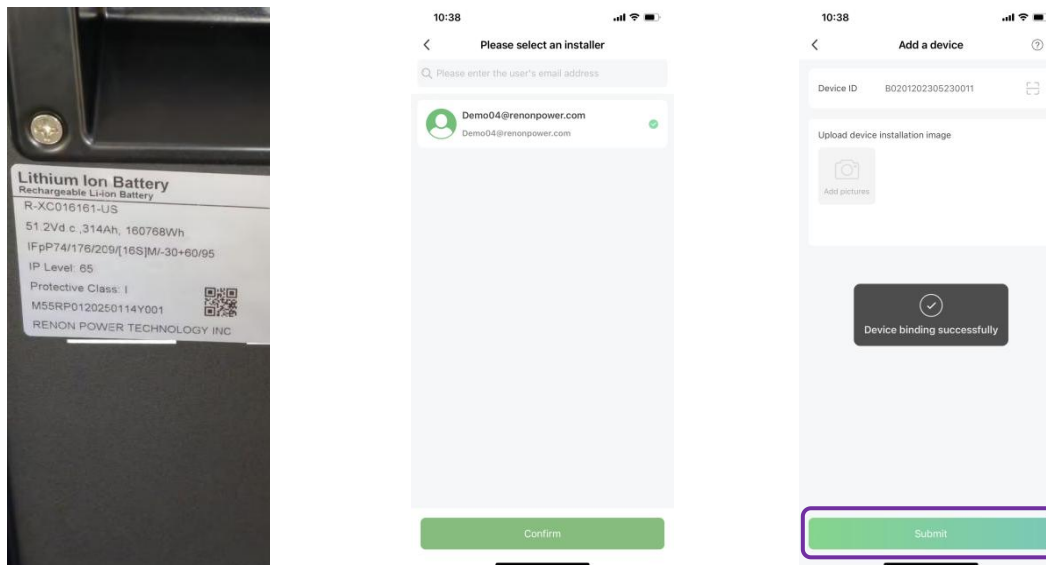

Figure 4.1.9. QR code, upper-level account & binding successfully

If the above methods are not successful, please contact Renon, email address: support@renon-usa.com, Renon Power Support: +1 (833) 736-6687. Be sure to write your account name/email address and device serial number clearly.

5) WiFi configuration

Set the inverter dial code to 63 (111111) as shown below before WiFi configuration.

Note: In a system with multiple batteries operating in parallel, you only need to configure the master battery unit (set to Address 1). Once configured, all other units will automatically retrieve network settings and connect seamlessly without manual intervention.

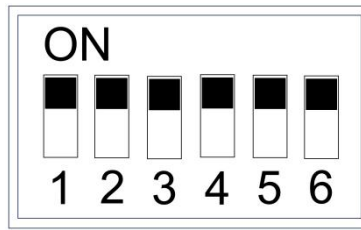

Turn to the “Me” page, click Network Configuration, then click Bluetooth, followed by WiFi configuration.

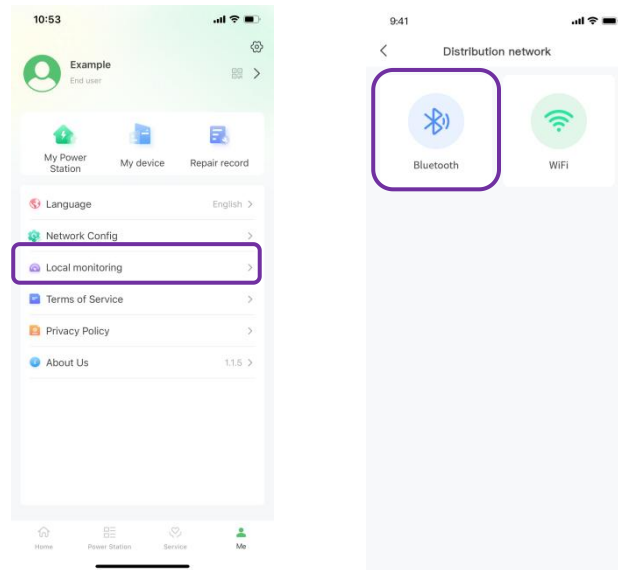

Figure 4.1.10. Bluetooth network setting

Enable Bluetooth on your mobile device, then select the detected device to access its Bluetooth network configuration page

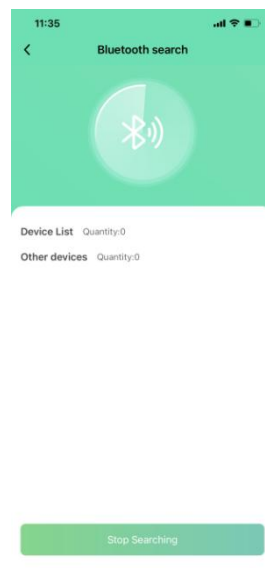

Figure 4.1.11. Connect battery Bluetooth

Enter your private WiFi credentials (SSID and password) to connect the master controller.

Note: Devices assigned to end users will auto-populate the authentication key.

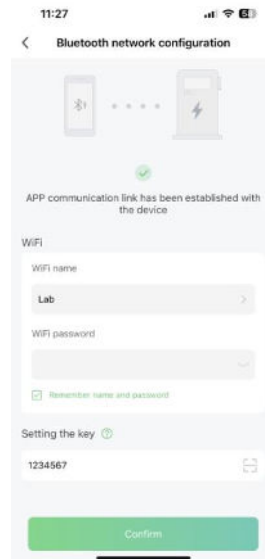

Figure 4.1.12. Connecting private WiFi

6) Create a power station

Navigate to the Power Station page on the app, create a new station by setting its name, type, pricing, superior view, address, and uploading station images.

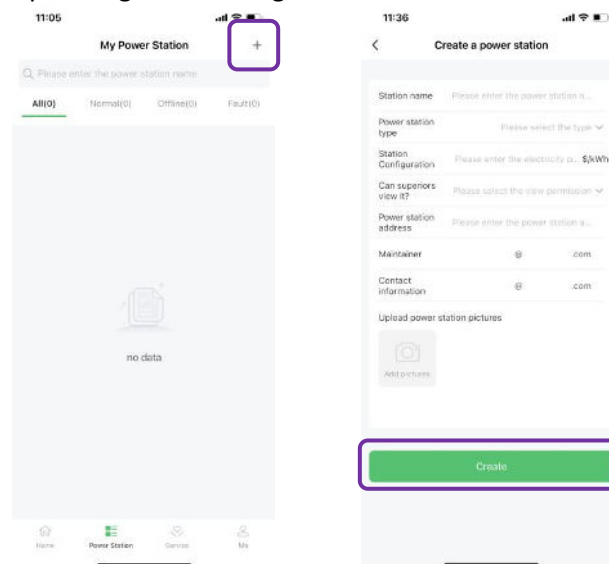

Figure 4.1.13. Create a new power station

After successful power station creation, select the newly created station to view its details, then tap "+" on the Binding Device page to add your desired device.

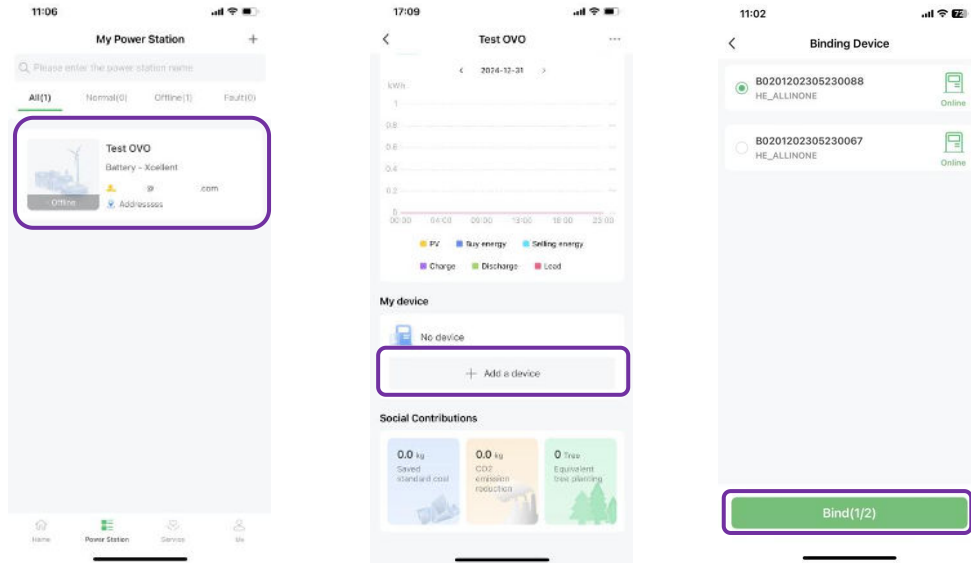

Figure 4.1.14. Manage your power station & Confirm your device

The device can be managed both through the app and the web portal (contact your installer for the website URL).

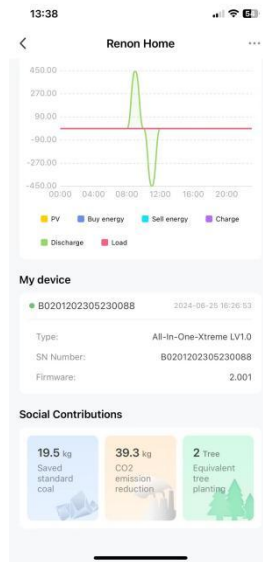

Figure 4.1.15. Manage your device

Once WiFi is connected, the device enables real-time monitoring of operational status, instantaneous power, and energy consumption (daily/cumulative) via the network platform or mobile app, while also supporting remote parameter configuration.

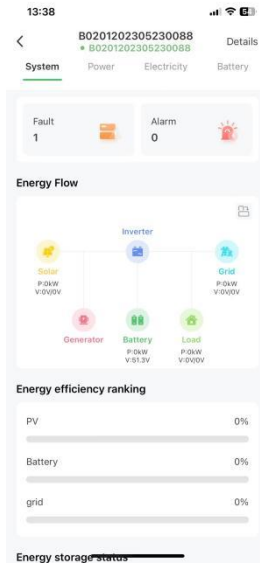

Figure 4.1.16. Monitoring device

Set the inverter dial code to match the inverter brand after WiFi configuration is complete (Please refer to the chapter **5.5.5 Inverter Dial Switch**).

7) Lock the waterproof cover

After completing the grid connection, lock and securely fasten the waterproof cover of the junction box. For detailed steps, refer to 3.2. Connection.

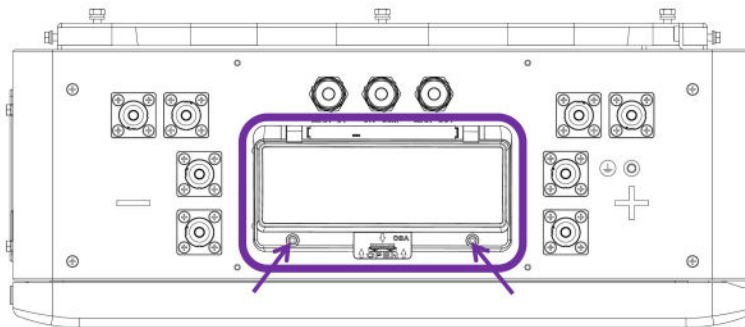

Figure 4.1.17. Lock waterproof cover of junction box

5 Battery Specifications

The Xcellent Plus is a lithium iron phosphate LFP battery-based energy storage product developed and produced by RENON, it can supply reliable power for nearly all kinds of household appliances and equipment.

The Xcellent Plus consists of a built-in BMS battery management system, which can manage and monitor cells information including voltage, current and temperature, used to limit the balance current between different batteries when parallel use to expand capacity and power to meet the requirements of longer power supporting duration and higher power consumption.

It is suspended on the wall in daily usage.

5.1 Product Features

- With a DC-DC converter inside, users can extend or change battery modules whenever they want, no need to consider the quality or SOC of old modules.
- The whole product is non-toxic, pollution-free and environmentally friendly.
- Cathode material is made from LiFePO₄ with safety, performance, and a long cycle life.
- The battery is small in volume, has light weight, plug-in embedded design module and is easy to install and maintain.
- Working temperature range is from -4°F and 122°F (-20°C to 50°C) with excellent discharge performance and cycle life.
- The battery management system (BMS) has protection functions including over-discharge, over-charge, and over-current and high/low temperature.
- The battery can self-discharge, up to 3 months without charging and offers excellent performance of shallow charge and discharge.
- The system can automatically manage battery charge and discharge state and save energy costs with various automation options.

5.2 Specifications

Item	R-XC016161-US / R-XC016161-H-US
Battery Chemistry	LiFePO4
Nominal Energy (kWh)	16
Nominal Capacity (Ah)	314
Max. Charging/Discharging Current (A)	190
Nominal Voltage (V)	51.2
Recommend Charging Voltage (V)	56.8
Max. Charging Voltage (V)	58.4
Discharge Cut-off Voltage (V)	43.2
Heating Power(W)	300
Heating Start Temperature (°F/°C)	41/5 (-H model only)
Operation Temperature (°F/°C)	Discharge: -4~131 / -20~55 Charge: 32~131 / 0~55
Safety Function	Over-charge, Over-discharge, Over-current, Low/High-temperature, Short-circuit Protections
Parallel Capacity	Maximum 31
Communication	RS485/CAN
Weight (lbs/kg) (Approx.)	337.31/153
Physical Dimensions (in/mm) (W*D*H)	22*8.3*48.3/560*210*1225 (±2) (Leveling feet not included)
Level of Protection	IP65
Altitude	≤4000m

Note: -H indicates that this product contains a heating film and has a heating film function.

5.3 External Introduction

5.3.1 Explosion-proof Valves

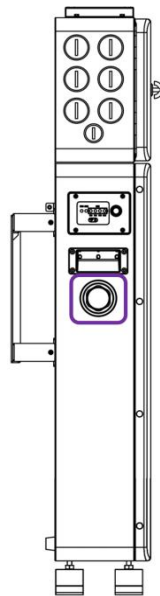

Figure 5.3.1. Explosion-proof valves

5.3.2 Power Button

The power button is used to power-on/power-off the device.

The power button is located in right corner of device.

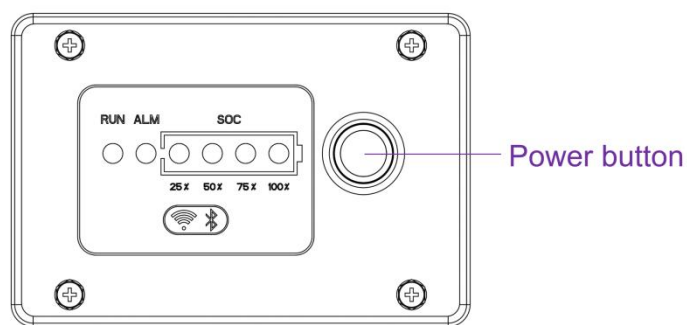

Figure 5.3.2. Button

5.3.3 LED

The LEDs are used to display current state.

The LEDs are located on the right side of device.

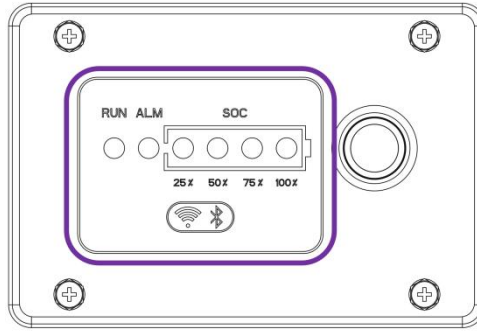

Figure 5.3.3. Light

No.	Item	Specification								
1	RUN (Blue)	Shut down: Off								
		WiFi disconnect router: On								
		WiFi has connected router: 0.5s on, 0.5s off								
		WiFi has connected cloud: 0.5s on, 1.5s off								
2	ALM (Red)	No protection, alarm, fault: off								
		Alarm: 0.5s on, 1.5s off								
		Protection: 0.5s on, 0.5s off								
		Fault: On								
3	Fault (Green)		Charging state				Discharging state/Idle			
		LED \ SOC (%)	SOC-25%	SOC-50%	SOC-75%	SOC-100%	SOC-25%	SOC-50%	SOC-75%	SOC-100%
		SOC=0	Blinking	Off	Off	Off	Off	Off	Off	Off
		0<SOC≤25	Blinking	Off	Off	Off	On	Off	Off	Off
		25<SOC≤50	On	Blinking	Off	Off	On	On	Off	Off
		50<SOC≤75	On	On	Blinking	Off	On	On	On	Off
		75<SOC≤100	On	On	On	Blinking	On	On	On	On

*Blinking: 0.5s on, 0.5s off

5.4 Function Introduction

5.4.1 Protection

The battery system is equipped with comprehensive protection features, including but not limited to overcharge/overdischarge protection, high/low temperature protection during charging/discharging, overcurrent protection during charging/discharging, and short circuit protection, ensuring the safety and stability of the battery under various usage conditions.

5.4.2 Heating

When the battery is equipped with a heating film, the system will continuously monitor cell temperature. If the lowest cell temperature is below 41°F (5°C), the system will automatically activate the heating function to enhance battery performance. The heating function requires the inverter to be connected to the grid for continuous operation; otherwise, heating will only operate for 5 minutes. Once the highest cell temperature exceeds 59°F (15°C), the heating function will automatically deactivate to prevent overheating.

5.4.3 Forced Discharge

When the system enters sleep mode due to undervoltage, users can manually activate the forced discharge mode by pressing the power button. Additionally, the system will automatically wake up at scheduled intervals to enter forced discharge mode, thereby activating the charger or inverter (the inverter requires grid connection) to provide necessary supplemental charging to the battery, ensuring its continued availability.

5.4.4 Full Charge

To ensure long-term battery health, the system monitors the battery's charging status. If the system detects that the battery has not reached a full charge for 30 consecutive days, it will automatically initiate a full charge process, charging the battery to its maximum capacity to maintain optimal performance.

5.4.5 Charging Self-Adaptation Control

The system will automatically reduce charging power when the battery is in low/high temperature conditions or low/high SOC.

5.4.6 Safety Lock

This device is equipped with a safety lock function. If the lock is triggered and cannot be resolved after self-attempts, promptly contact technical support personnel for unlocking assistance.

5.5 Interface Information

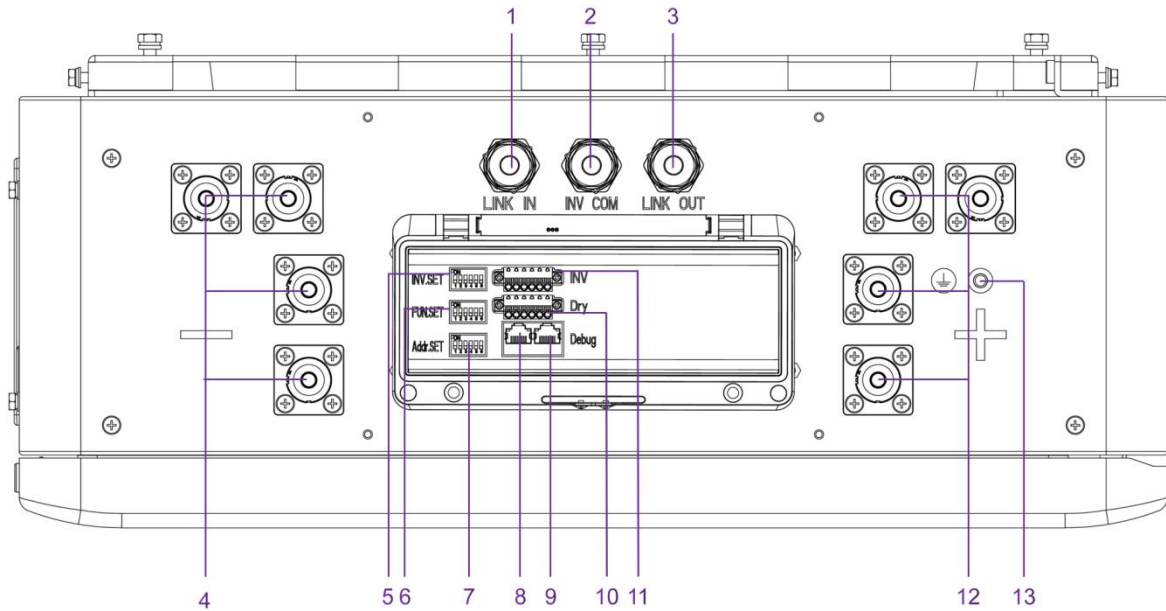

Figure 5.5.1. Battery ports

No.	Instructions	No.	Instructions
1	LINK IN	8	Inverter Port
2	INV COM	9	Debug Port
3	LINK OUT	10	Dry Contact
4	Power Negative	11	INV
5	INV.SET	12	Power Positive
6	FUN.SET	13	Ground
7	Addr.SET		

5.5.1 LINK IN Parallel Communication Port

Terminal type: RJ45

Usage: Communicates with the last battery when parallel used.

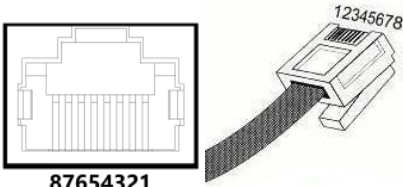
Port definitions	RJ45 Pin	Function
	1	BMS_CAN1L
	2	BMS_CAN1H
	3	BMS_CC_GND
	4	BMS_CC_GND
	5	BMS_PW_IN1
	6	BMS_CC_GND
	7	BMS_XUNZIN- /Emergency stop node 1
	8	BMS_XUNZIN+ /Emergency stop node 2

5.5.2 INV COM Port

Terminal type: RJ45

Usage: Communicates with the inverter.

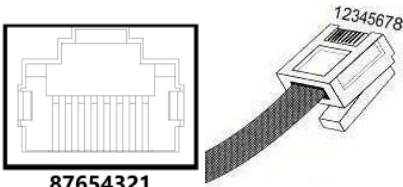
Port definitions	RJ45 Pin	Function
	1	RS485_2A
	2	RS485_2B
	3	COM_SGND
	4	CAN2H
	5	CAN2L
	6	COM_SGND
	7	RS485_2A
	8	RS485_2B

5.5.3 LINK OUT Parallel Communication Port

Terminal type: RJ45

Usage: Communicates with the next battery when parallel used.

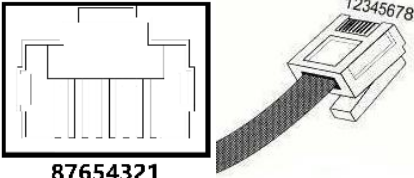
Port definitions	RJ45 Pin	Function
	1	BMS_CAN1L
	2	BMS_CAN1H
	3	BMS_CC_GND
	4	BMS_PW_OUT2
	5	BMS_PW_OUT1
	6	BMS_CC_GND
	7	BMS_XUNZOUT-
	8	BMS_XUNZOUT+

5.5.4 Inverter Communication Port

Terminal type: RJ45

Usage: Communicate with inverter.

Definition of battery side as below:

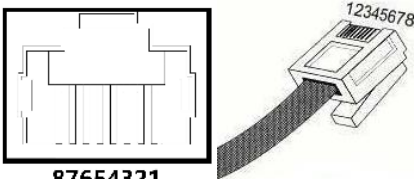
Port definitions	RJ45 Pin	Function
	1	RS485_2B
	2	RS485_2A
	3	COM_SGND
	4	WAKEUP +
	5	WAKEUP -
	6	COM_SGND
	7	CAN2H
	8	CAN2L

5.5.5 Debug Port

Terminal type: RJ45



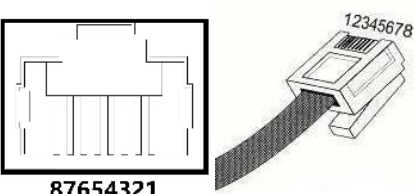









Usage: Debug port of the system which used by technician only.

Port definitions	RJ45 Pin	Function
	1	BMS_CAN1L
	2	BMS_CAN1H
	3	BMS_RS232_RX
	4	BMS_CC_GND
	5	BMS_CC_GND
	6	BMS_RS232_TX
	7	IN_CANL
	8	IN_CANH

5.5.6 Inverter Dial Switch

Code 0~26 of this Dial Switch are used to match which brand of inverter is using.

The definitions of code 0 ~ 26 are shown as Inverter dial code table.

Code	Dial Switch Position	Brand	Logo
0		APP setting (Default: Renon Flex)	
1		Renon	
2		Schneider Gateway	
3		Sol-Ark	
4		Solis	
6		Studer Xtender	

7		Victron	
8		SMA	
9		Sermatec	
10		Sofar	
11		DEYE	
12		Growatt SPF	
13		Growatt SPH	
14		Must	
15		MEGAREVO	
16		SAJ	
17		Aiswei	
18		Phocos	
22		Voltronic Power	
24		Afore	
25		Lux Power	
26		CHISAGE ESS	

5.5.7 Function Dial Switch



The dial switch settings for a single are as below:

Single device	Usage
Code	

5.5.8 Address Dial Switch

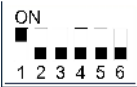
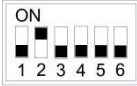
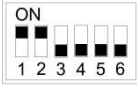
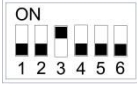
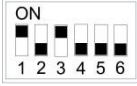
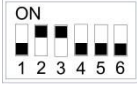
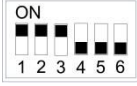
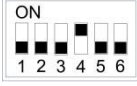
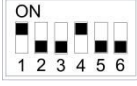
- 1) Use this Dial Switch to set the address of each battery and then turn on to activate the system when it needs to be in parallel with other battery units.
- 2) When the system only has one battery, dial the address to 1.
- 3) When the system is used in parallel mode, set the address start from 1, and increase by the number of battery units in order to communicate with other battery.
- 4) Only the battery with address of 1 is able to communicate with the inverter.
- 5) The illustration of dialing shown Address dial code table:

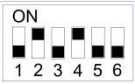
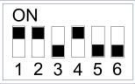
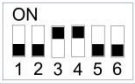
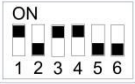
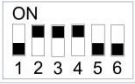
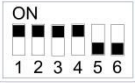
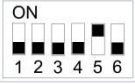
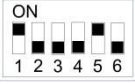
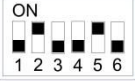
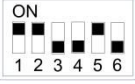
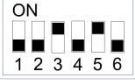
Code	Dial Switch Position	Definition
1		Set as battery 1 (communicate with inverter by this battery)
2		Set as battery 2
3		Set as battery 3
4		Set as battery 4
5		Set as battery 5
6		Set as battery 6
7		Set as battery 7
8		Set as battery 8
9		Set as battery 9

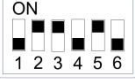
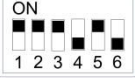
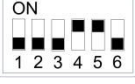
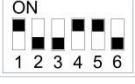
10		Set as battery 10
11		Set as battery 11
12		Set as battery 12
13		Set as battery 13
14		Set as battery 14
15		Set as battery 15
16		Set as battery 16
17		Set as battery 17
18		Set as battery 18
19		Set as battery 19
20		Set as battery 20
21		Set as battery 21
22		Set as battery 22
23		Set as battery 23
24		Set as battery 24
25		Set as battery 25

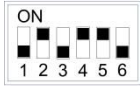
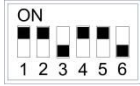
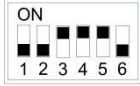
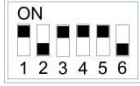
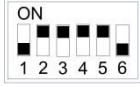
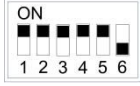
26		Set as battery 26
27		Set as battery 27
28		Set as battery 28
29		Set as battery 29
30		Set as battery 30
31		Set as battery 31

5.5.9 Dry Contact

Terminal type: 6-Pin terminal block

This is for General-purpose input & output (GPIO) which reserved for future communication and used for an uncommitted digital signal pin on an integrated circuit or electronic circuit (e.g. MCUs/MPUs) board which may be used as an input or output, or both, and is controllable by software.

Defined as below:

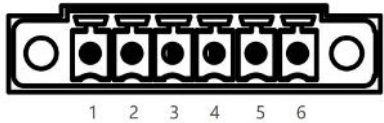
6pin Terminal	Pin	Usage
	1	BMS_NO1
	2	BMS_COM1
	3	BMS_NO2
	4	BMS_COM2
	5	WAKEUP +
	6	WAKEUP -

5.5.10 INV Communication Port

Terminal type: 6-Pin terminal block

Usage: Reserved for direct connection with inverter, same function as the RJ45 port (chapter " Inverter Communication Port (RJ45)"), only one of these two need to be used, leave it open if not used.

Defined as below:

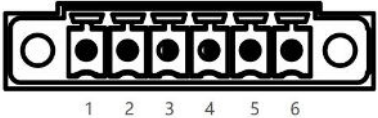
6pin Terminal	Pin	Usage
	1	RS485_2B
	2	RS485_2A
	3	COM_SGND
	4	CAN2L
	5	CAN2H
	6	COM_SGND





5.5.11 Power Positive & Negative

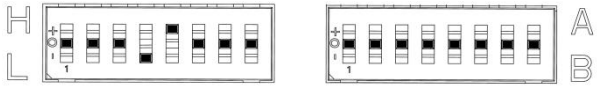
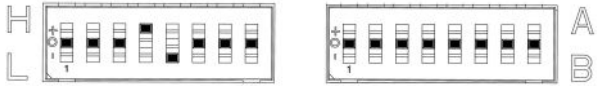
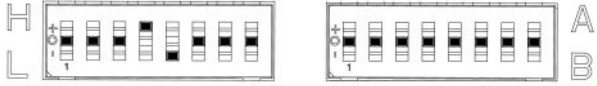

Positive and negative terminals are be used with connectors.

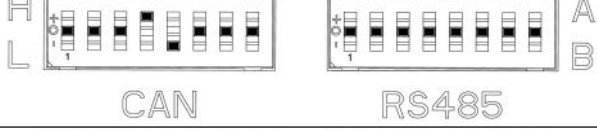
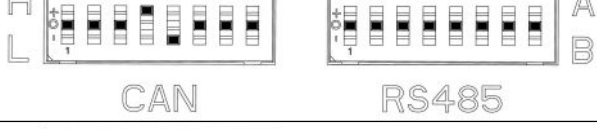
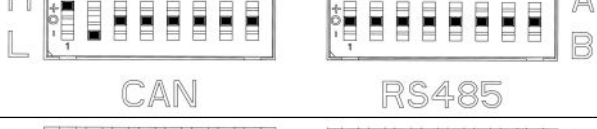
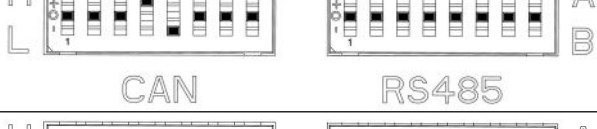
5.5.12 Dial Code Switch

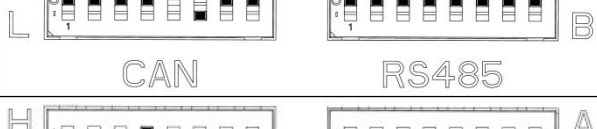
If you are using the pin order select box, please refer to the table below to set the dial switch, according to the inverter brand. If the inverter brand is not shown in the table, please refer to the inverter manual or consult Renon's engineer.

Dail switch position	Inverter brand	Comm Mode
 CAN RS485	Schneider Gateway	CAN
 CAN RS485	Sol-Ark	CAN
 CAN RS485	Solis	CAN

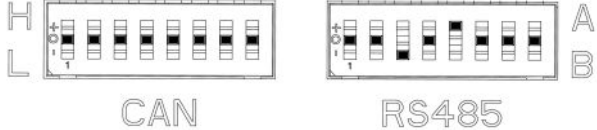
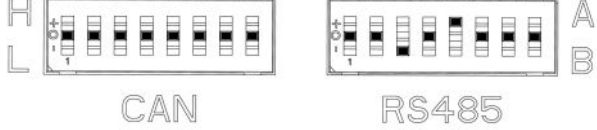
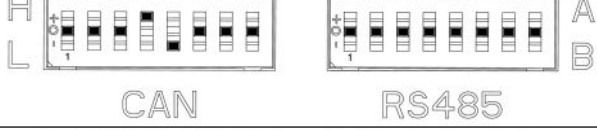
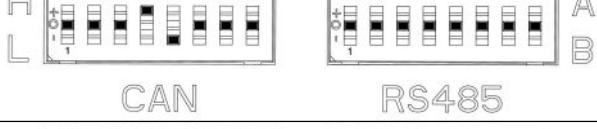
 <p>CAN RS485</p>	Studer	CAN
 <p>CAN RS485</p>	Victron	CAN
 <p>CAN RS485</p>	SMA	CAN
 <p>CAN RS485</p>	Sermatec	CAN
 <p>CAN RS485</p>	Sofar	CAN
 <p>CAN RS485</p>	DEYE	CAN
 <p>CAN RS485</p>	Growatt SPF	RS485
 <p>CAN RS485</p>	Growatt SPH	CAN
 <p>CAN RS485</p>	Must	CAN
 <p>CAN RS485</p>	MEGAREVO	CAN
 <p>CAN RS485</p>	SAJ	CAN
 <p>CAN RS485</p>	Aiswei	CAN

 <p>CAN RS485</p>	Phocos	RS485
 <p>CAN RS485</p>	Voltronic Power	RS485
 <p>CAN RS485</p>	Afore	CAN
 <p>CAN RS485</p>	Lux Power	CAN
 <p>CAN RS485</p>	CHISAGE ESS	CAN

5.5.13 Emergency Stop

The first battery (Address 1)'s LINK IN port (Pins 7-8) can be connected to the normally open (NO) contacts of an external emergency stop button. When activated, this will disconnect all battery outputs.

When multiple batteries are connected in parallel, the ESS disconnect only needs to be connected to the master battery.

If the inverter is equipped with Rapid Shutdown (RSD) capabilities, the emergency stop feature can initiate this function. It is recommended to check with the local Authority Having Jurisdiction (AHJ) and the National Electrical Code (NEC) for compliance.

6 Troubleshooting & Maintenance

6.1 Regular Maintenance

- 1) Check the battery modules every 3 months to verify whether there are damages.
- 2) Check the battery modules every 3 months to verify that the operating parameters are normal and there is no abnormal heating.
- 3) Fully charge and discharge the battery system every 3 months.
- 4) Clean the battery modules with a dry rag once a month.

6.2 Troubleshooting

Phenomenon	Possible Causes of Failure
Unable to turn on the battery	<ol style="list-style-type: none"> 1. Try to charge the battery with the activation charging function on the inverter when power is on.
Unable to find the battery on the app or the Cloud	<ol style="list-style-type: none"> 1. Make sure the WiFi antenna is tightened properly; 2. Make sure the SSID & PASSWORD of your private WiFi is correct, please enter information case-sensitively without space; 3. Make sure the signal is strong enough; 4. Make sure it's working; 5. Make sure installer has added your products to your account; 6. Try to restart the router.
No output after power on.	<ol style="list-style-type: none"> 1. Make sure the address dial code setting is correct, refer to the chapter of address dial code; 2. Make sure SOC is not 0%, otherwise charge battery.
Unable to communicate with inverter	<ol style="list-style-type: none"> 1. Make sure the connection of communication cable and power cable is correct, refer to the chapter of connection of cable and power; 2. Make sure the address dial code of the master controller connected to inverter is 1; 3. Make sure the inverter dial code of the master controller connected to inverter is correct, refer to the chapter of inverter dial code; 4. If you are using a pin order select box, please verify that the dialing switch is configured correctly.

Unable to be charged by inverter	<ol style="list-style-type: none"> 1. Make sure power cable connection is correct; 2. Check whether inverter has faults; 3. Check whether grid or PV is available; 4. Make sure Time of Use of the inverter setting is correct; 5. Make sure charging voltage and charging current setting of the inverter match the parameters of the battery; 6. Check the battery low or high temperature protection alarm; 7. Check the over current protection alarm; 8. Make sure the SOC value is below 96% (default value).
Unable to discharge while SOC is not zero.	<ol style="list-style-type: none"> 1. Make sure the connection of cables is correct and circuit breaker is ON; 2. Check whether inverter has faults; 3. Make sure the inverter setting is not in back up mode; 4. Check whether SOC is lower than the shutdown value of the inverter; 5. Check the battery low or high temperature protection alarm; 6. Check the over current protection alarm.
SOC value change instantly.	<ol style="list-style-type: none"> 1. It is normal that the SOC value will change when the number of parallel modules changes; 2. It is normal that the SOC value will be calibrated when the battery has been fully charged, or deeply discharged.

6.3 Status Code

The following status codes are displayed on the cloud platform.

6.3.1 Warning Codes

Code	Warning type	Investigation & troubleshooting
W1	Battery cell undervoltage alarm	1. Low voltage level and needs to be charged.
W2	Charge overcurrent alarm	<ol style="list-style-type: none"> 1. Restore to factory setting; 2. Make sure the inverter setting of max current does not exceed the max charge current of the battery.
W3	Discharge overcurrent 1 alarm	1. Make sure the power of load does not exceed the power of battery.
W4	High charge temp alarm	1. Make sure the battery temperature shown on the inverter or the app is below 131°F (55°C), otherwise turn off the battery until the temperature is below 131°F (55°C), and then try to charge battery.
W5	High discharge temp alarm	1. Make sure the battery temperature shown on the inverter or the app is below 131°F (55°C), otherwise turn off the battery until the temperature is below 131°F (55°C), and then try to discharge battery.

W6	Low charge temp alarm	1. Make sure the battery temperature shown on the inverter or the app is above 32°F (0°C), otherwise turn off the battery until the temperature is above 32°F (0°C), and then try to charge battery.
W7	Low discharge temp alarm	1. Make sure the battery temperature shown on the inverter or the app is above -4°F (-20°C), otherwise turn off the battery until the temperature is above -4°F (-20°C), and then try to charge battery.
W8	High ambient temp alarm	1. Make sure the ambient temperature of the battery is below 122°F (50°C).
W9	High voltage difference alarm	1. Restart the battery, and if error code W9 still remains or reappears, contact your installer.
W13	Low total voltage alarm	1. Low voltage level and needs to be charged
W14	Low ambient temp alarm	1. Make sure the ambient temperature of the battery is above -13°F (-25°C).
W15	High MOS temp alarm	1. Reduce the ambient temperature and restart the battery.
W16	Battery cell overvoltage alarm	1. High voltage level and needs to be discharged.
W17	High total voltage alarm	1. High voltage level and needs to be discharged.
W18	Low SOC alarm	1. Low SOC and needs to be charged.
W22	Positive connector high temp alarm	1. Restart the battery, and if error code W22 still remains or reappears, contact your installer.
W23	Negative connector high temp alarm	1. Restart the battery, and if error code W23 still remains or reappears, contact your installer.
W31	Heating film activation failure fault	1. Restart the battery, and if error code W31 still remains or reappears, contact your installer.
W32	Heating film deactivation failure fault	1. Restart the battery, and if error code W32 still remains or reappears, contact your installer.
W400	PCS disconnection	1. Restart the battery, and if error code W400 still remains or reappears, contact your installer.

6.3.2 Error Codes

Code	Error Type	Investigation & troubleshooting
F102	Battery cell fault	1. Restart the battery, and if error code F102 still remains or reappears, contact your installer.
F103	NTC fault	1. Restart the battery, and if error code F103 still remains or reappears, contact your installer.
F104	Current sensor fault	1. Restart the battery, and if error code F104 still remains or reappears, contact your installer.
F106	Short circuit fault	1. Make sure the external connection for both battery and inverters are proper; 2. Disconnect all external connections and restart the battery, and if error code F106 still, contact your installer.
F108	Heating fault	1. Restart the battery, and if error code F108 still remains or reappears, contact your installer.
F109	Battery module conflict	1. Restart the battery, and if error code F109 still remains or reappears, contact your installer.
F111	Charge MOS fault	1. Restart the battery, and if error code F111 still remains or reappears, contact your installer.
F112	Discharge MOS fault	1. Restart the battery, and if error code F112 still remains or reappears, contact your installer.
F114	Precharge fault	1. Restart the battery, and if error code F114 still remains or reappears, contact your installer.
F116	Battery reverse connection fault	1. Restart the battery, and if error code F116 still remains or reappears, contact your installer.
F118	Address non-1 fault	1. Restart the battery, and if error code F118 still remains or reappears, contact your installer.
F119	Address break-sign failure	1. Restart the battery, and if error code F119 still remains or reappears, contact your installer.
F120	Pack disconnect fault	1. Restart the battery, and if error code F120 still remains or reappears, contact your installer.
F123	Microelectronic fault	1. Restart the battery, and if error code F123 still remains or reappears, contact your installer.

F130	Master and EMS communication lost	1. Restart the battery, and if error code F130 still remains or reappears, contact your installer.
F131	Pack disconnect fault	1. Restart the battery, and if error code F131 still remains or reappears, contact your installer.
F132	EMS SN is empty	1. Restart the battery, and if error code F132 still remains or reappears, contact your installer.
F135	Pack SN is empty	1. Restart the battery, and if error code F135 still remains or reappears, contact your installer.
F200	Battery cell undervoltage safety lock	1. Restart the battery, and if error code F200 still remains or reappears, contact your installer.
F201	Battery cell high voltage safety lock	1. Restart the battery, and if error code F201 still remains or reappears, contact your installer.
F202	Charge high temp safety lock	1. Restart the battery, and if error code F202 still remains or reappears, contact your installer.
F203	Charge low temp safety lock	1. Restart the battery, and if error code F203 still remains or reappears, contact your installer.
F204	Discharge high temp safety lock	1. Restart the battery, and if error code F204 still remains or reappears, contact your installer.
F205	Discharge low temp safety lock	1. Restart the battery, and if error code F205 still remains or reappears, contact your installer.
F206	Charge overcurrent safety lock	1. Restart the battery, and if error code F206 still remains or reappears, contact your installer.
F207	Discharge overcurrent safety lock	1. Restart the battery, and if error code F207 still remains or reappears, contact your installer.

6.3.3 Protection Codes

Code	Error Type	Investigation & troubleshooting
P1	Battery cell undervoltage protection	1. Low voltage level and needs to be charged.
P2	Overcurrent charge protection	1. Restore to factory setting; 2. Make sure the inverter's setting of max current does not exceed the max charge current of the battery.
P3	Overcurrent discharge protection	1. Make sure the power of load does not exceed the power of battery.
P4	High charge temp protection	1. Make sure the battery's temperature shown on the inverter or the app is below 125.6°F (52°C), otherwise turn off the battery until the temperature is below 125.6°F (52°C), and then try to charge battery.
P5	High discharge temp protection	1. Make sure the battery's temperature shown on the inverter or the app is below 125.6°F (52°C), otherwise turn off the battery until the temperature is below 125.6°F (52°C), and then try to discharge battery.
P6	Low charge temp protection	1. Make sure the battery's temperature shown on the inverter or the app is above 32°F (0°C), otherwise turn off the battery until the temperature is above 32°F (0°C), and then try to charge battery.
P7	Low discharge temp protection	1. Make sure the battery's temperature shown on the inverter or the app is above -4°F (-20°C), otherwise turn off the battery until the temperature is above -4°F (-20°C), and then try to charge battery.
P8	High ambient temp protection	1. Make sure the ambient temperature of the battery is below 122°F (50°C).
P9	Excessive voltage difference protection	1. High voltage level, and needs to be discharged.
P13	Low total voltage protection	1. Low voltage level, and needs to be charged.
P14	Low ambient temp protection	1. Make sure the ambient temperature of the battery is above -13°F (-25°C).
P15	High MOS temp protection	1. Reduce the ambient temperature, and restart the battery.
P16	Battery cell overvoltage protection	1. High voltage level, and needs to be discharged.
P17	High total voltage protection	1. High voltage level, and needs to be discharged.

P18	Low SOC protection	1. Low voltage level, and needs to be charged.
P19	Overcurrent discharge 2 protection	1. Make sure the power of the load does not exceed the power of battery.
P22	Positive connector high temp protection	1. Reduce the ambient temperature, and restart the battery.
P23	Negative connector high temp protection	1. Reduce the ambient temperature, and restart the battery.
P30	Charger overvoltage protection	1. Restart the battery, and if error code P30 still remains or reappears, contact your installer.

P/N: 118.601.00.0131



Renon Power Technology Inc.

5900 Balcones Drive Suite 100, Austin, TX 78731 USA

Renon Power Solutions Sp.z o.o.

ul. ELBLĄSKA 1, 93-459, ŁÓDŹ, POLAND

Renon Power Technology B.V.

Rietbaan 10, 2908 LP Capelle aan den IJssel

Renon Power 株式会社

東京都中央区日本橋箱崎町 20-5 VORT 箱崎 5F



WhatsApp



LinkedIn



Website